

South Carolina Department of Education

School Bus Technical Training Series

School Bus Inspection



This workbook belongs to: _____

Issued on ___/___/___

South Carolina Department of Education Office of Transportation

Vehicle Inspection Program

This program is established to ensure the greatest degree of **safety** for vehicles used to provide and support the Student Transportation Programs under the direction of the South Carolina Department of Education. The SCDE Office of Transportation shall be responsible for administering and monitoring this inspection program to ensure compliance with the procedures as set forth herein.

This manual has been structured to provide the necessary information and criteria for operating a comprehensive Vehicle Inspection Program. Along with the program requirements, this manual also contains instructions for electronic record keeping, and specific procedures for inspecting the various vehicle components/systems. Procedure for addressing district responsible issues.

The certification process and inspection criteria were developed by the Vehicle Inspection Committee. Current committee members are:

James Miller – Engineering Associate	Wayne Southard - Engineering Associate
Patrick Nesmith- Engineering Associate	William McDaniel - Engineering Associate
Justin Roach- Engineering Associate	Randy Linz – Engineering Associate

Justin Peake – Fairfield – Shop Foreman	Steve Cox – Abbeville – Shop Foreman
Wilbur Adkins- Lancaster –Shop Foreman	Jerry Nesmith – Williamsburg-Shop Foreman
Timmy Baird –Lee – Asst Shop Foreman	Tim Whitt – Greenwood – Shop Foreman

Robert Hoffman – Area Supervisor -Area I	Trey Thomas – Area Supervisor - Area III
Wayne Eadon – Area Supervisor – Area II	Nikki Tessner – Area Supervisor – Area IV

Marion Mack – Richland - County Supervisor	
Brian West – Chester - County Supervisor	

Mike Bullman – Director of Transportation	Luke Patrick -Director of Maintenance
Theresa Taylor– Training Coordinator	
Crystal Leaphart– Safety and Training Director	

This manual, as provided, should clarify many of the gray areas that occur when operating a Vehicle Inspection Program. However, this manual will not answer all technical or interpretive questions, nor will it eliminate the need for trained personnel to exercise professional judgment when performing vehicle inspections.

The emphasis of ALL vehicle inspections is “**SAFETY**” and in every case, the **CERTIFIED INSPECTORS** must exercise judgment that will ensure the greatest degree of safety for the vehicle operators, passengers, and other motorists.

Ensure **All** Air Conditioners are working as they should on your fleet of buses. Per SCDE policy, if the Air Conditioner is not working on a SPED bus, that vehicle is **Out of Service**. If the Air is not working on a GenEd bus, it is a **high** priority repair. **In both of these cases, the district should be notified of the repair timeline immediately and updated.** Also, be sure that the A/C systems are being checked during each in-quarterly inspection, Annual repair, and Summer Maintenance.

REMEMBER, it is our obligation to ensure a comfortable and safe environment for students and drivers. A PROPERLY functioning AC system not only helps regulate the temperature inside the bus, preventing overheating and discomfort, it also ensures that air quality remains high by filtering out pollutants and allergens, reducing the risk of respiratory issues among passengers. Additionally, a cool and comfortable environment can promote focus and attentiveness among students, leading to better behavior and academic performance.

Overall, maintaining the air conditioning on a school bus is not only beneficial for passenger comfort but also for their health and well-being while traveling to and from school.

Resources used in the preparation of this manual are as follows: **South Carolina School Bus Specifications, National Standards for School Buses, Federal Motor Vehicle Safety Standards, Service and Repair Manuals from various school bus body and chassis manufacturers’, and other Industry Standards for Maintenance and Repair Procedures.**

South Carolina statutes that are relevant to the inspection of school buses are as follows:

SECTION 59-67-270. Inspection of Buses

(A)(1) All publicly owned or leased school buses, including buses owned or leased by a public school district, must be inspected annually in compliance with either the State Department of Education's annual school bus inspection program or the federal Department of Transportation annual inspection program if the standards of the federal inspection program meet or exceed the standards of the State's program. The State Department of Education shall assist school districts using the Department of Education's program in this requirement by providing the training and certification of a limited number of personnel designated by a school district to perform the inspection, providing the inspection manuals and forms, and supplying the inspection certificate stickers for the school buses. The State Department of Education's assistance must be free of charge. Any savings resulting from the ability to be inspected by either the State Department of Education or the federal Department of Transportation shall be expanded on accountability programs set forth in Chapter 18 of this title."

(2) All privately owned vehicles designed and used to transport ten or more pre-primary, primary, or secondary students to or from school, school related activities, or childcare must be inspected annually. Inspections for these privately-owned vehicles must comply with applicable federal inspection requirements. A copy of the vehicle inspection report must always be kept on these vehicles.

(3) The owner or lessee of a school bus shall be solely responsible for the implementation and accountability of school bus inspections.

(B) All school buses are subject to inspection at any time or place by officers of the State Transport Police or inspection forces. A school bus may not continue in operation in the transportation of students when the annual inspection is more than twelve months old, or the school bus is found to be unsafe after any inspection until the unsafe conditions disclosed by the inspection have been corrected.

SECTION 59-67-280. Penalties

The doing of anything prohibited by this article or failing to do anything required by this article shall be a misdemeanor, punishable by a fine of not less than five dollars or more than one hundred dollars or imprisonment in the county jail for not less than five or more than thirty days.

Inspection Requirements

The County Supervisor of every SCDE vehicle maintenance facility shall be responsible for ensuring that each vehicle assigned to their facility for maintenance is inspected in accordance with the procedures established herein.

Each assigned vehicle that is listed in an Active Route or Active Spare status must be inspected a **minimum** of once Quarterly or **4000 miles**. Any vehicle that is **NOT INSPECTED WITHIN THE QUARTER WILL BE OUT OF SERVICE**. These inspections must be performed by an inspector that has been certified by the South Carolina Department of Education, Office of Transportation (SCDE). Additionally, the **County Supervisor** shall be required to participate in a minimum of **10 buses** per calendar month.

The primary inspector for any given maintenance facility shall be the FOREMAN / ASSISTANT FOREMAN. However, assistance in completing the required inspections may be provided by any SCDE Certified Inspector. If SCDE personnel that are not certified as an inspector are assisting a Certified Inspector, these individuals may inspect vehicle components/systems provided the Certified Inspector they are assisting ensures that they are properly trained in the inspection procedures and the associated repair/out of service criteria. In such cases, the Certified Inspector remains responsible for the proper inspection of all items.

For the purposes of this program:

- Use of the term “**vehicles**” shall be understood as including all **school buses/boat and support vehicles/equipment**.
- Use of the term “**inspection**” shall be understood to mean a full and complete inspection as defined in the certification program.
- It should be noted that an “**inspection**” cannot be completed on a vehicle that is non- operational (power train or primary component/system inoperable).

Certification

Certification for the SCDE Vehicle Inspection Program will be broken down into two categories:

- **Vehicle Inspection Program Supervisor**
- **Vehicle Inspector**

Certifications for both categories shall be valid for five (5) years from the date of issue and will require re-certification every five (5) years. Re-certification will only require scoring at least a 70% on a written exam.

Vehicle Inspection Program Supervisor - This certification will ensure that the County Supervisors are knowledgeable of the program requirements within our maintenance software and that they have a general knowledge of how to conduct an actual vehicle inspection using the inspection manual and associated criteria. This certification will require the individual to attend a SCDE training seminar and score at least a 70% on a written exam.

The Area Supervisors, along with the County Supervisor for each maintenance facility, shall be required to maintain certification as a Vehicle Inspection Program Supervisor.

Vehicle Inspector - This certification will ensure that the inspectors are knowledgeable in the processes required to conduct an actual vehicle inspection and the use of the inspection manual with associated criteria. They will also have a general knowledge of the program administrative requirements. To be certified as a vehicle inspector, an individual must attend an SCDE training seminar and score at least a 70% on both a written and hands-on test.

The Engineering Associates, along with the Foreman/Assistant Foreman for each maintenance facility shall be required to maintain certification as a Vehicle Inspector. Additional employees may be identified by the County Supervisor to attend the Vehicle Inspector training/certification seminars.

Records

Once the inspector(s) completes the In-Quarterly, the inspection work order should be closed.

- **Out-of-service defects will be recorded on an out-of-service repair order.**
- **All non-out of service defects will be recorded into the maintenance software on an extended repair work order.**
- **The shop should strive to complete all inspection repairs prior to the next Quarterly inspection.**
- **For the inspection to be valid, at least one certified inspector must participate.**

Certifications: Each facility shall maintain a valid copy of the certificate or a current list of names, certification numbers, and expiration dates, for each certified Vehicle Inspection Program Supervisor and Inspector in their area, to include vendors conducting inspections to district vehicles. A copy of these certificates shall be maintained in front of the first drawer in the foreman's file cabinet in a file folder labeled CERTIFICATES.

School District Notification of Vehicle Defects: The County Supervisor / Shop Foreman shall notify the district in writing of any issues for which they are responsible for taking corrective actions.

In- Quarterly

Shop Foreman / certified inspector must complete. In- Quarterly work order will include the Date, Vehicle #, Mileage and Hours and test results.

Vehicle Inspection Defects/Repairs

Once the vehicle has been inspected **ALL DEFECTS / OUT OF SERVICE DEFECTS AND REPAIRS MUST BE RECORDED** in the current **maintenance software program as an extended repair work order**. Each defect shall have a task created adding notes describing **ALL** defects.

1. A **repair defect** is noted if the item inspected exhibits a type of defect identified under the “Repair” column of this manual or which does not affect the safe operation of the vehicle. This indicates that the item should be repaired in a reasonable amount of time, but the vehicle may continue to operate.
2. An “**Out of service defect**” is noted if the item inspected exhibits a type of defect identified under the “Out of Service” column of this manual or which could affect the safe operation of the vehicle. This indicates that the vehicle is to be placed in an Out of Service status and must not be allowed to operate until appropriate repairs have been made to correct the defect.

Inspection Items – This section is broken into four main categories (**Inside Vehicle, Outside Vehicle, Engine Compartment, and Underneath Vehicle**) based on the areas of the vehicle to be inspected. This simplifies the method of grouping the various items. Under each of the main categories, there are specific items listed that are to be inspected. Items that are shown in bold type are primary items. Items that are shown in regular type are detailed items or functions that are specific to the primary items.

VEHICLE AND EQUIPMENT REMAINING OEM STYLE AND EQUIVALENT

Vehicles and equipment should be repaired in such a way that they conform to the standard specifications for the particular vehicle or equipment. Therefore, when it becomes necessary to make repairs to buses, support vehicles or equipment, the repairs should be made so that the item will be the same as when it was received new.

This practice will ensure the highest level of safety and standardization, while ensuring warranty, EPA, NHTSA, OSHA and FMVSS compliance.

It may be necessary that we make repairs or changes that are not consistent with the manufacturer's recommendations. If this is the case, these repairs must be discussed and approved by the assigned Engineering Associate. In such cases, a decision will be made at the state level prior to the individual shops making changes.

All support vehicles shall be kept clean and presentable, so as to represent the agency and its mission in a positive and professional manner.

Under no circumstances should an SCDE employee make any changes to vehicles or equipment that is not consistent with OEM recommendations without prior approval from your assigned Engineering Associate or the State Office.

Vehicle # _____ Mileage _____ Hours _____

This form is to be utilized for transitional recording of vehicle inspection faults or defects. Once information has been recorded in the current maintenance software this form will be **discarded**.

Status Code: **No Mark** = Item OK **X** = Needs Repair **O** = Out of Service

Status Code	INSPECTION ITEMS	COMMENTS (Note Specific deficiencies)
	A. INSIDE VEHICLE	
	1. Stepwell/Grab Rails - Decals, Search, Electronic Recording, Condition, Tread, Modification	
	2. Emergency Equipment - Fire Ext., First Aid Kit, Body Fluid Cleanup Kit, Spill Kit, Reflectors, Webbing Cutter, Stop the Bleed Kit	
	3. Registration, Insurance Card, Holder - Present, Condition	
	4. Neutral Safety Switch, Shifter, Touch Pad - Operation, Detent, Indicator	
	5. Dash Decals - Elec. Booster, Glow Plug, Walk Through, Lift, Mirror, Back-Up	
	6. Engine Controls - Key Switch, Accelerator, Engine Shutdown, Fast Idle Switch, Starter	
	7. Gauges, Indicators, Lights, & Buzzers - Speed/Odometer, Oil, Temp, Fuel, Volt/Amp, Tach, Hour Meter, Trans. Temp, Pall Filter, Low Oil, High Temp, Check Engine, High Beam, Turn Signal/4-Way, Wait to Start, Dash Lights	
	8. Air Brake System - Gauge(s), Build-Up, Governor, Park Brake, Air Leaks, Low Air Warning, PP-1 Pop-Off, Pedal, Anti-Lock Brake, Intellipark	
	9. Hydraulic Brake System - Warning Light, Gauge, Pedal, Travel/Adjustment, Feel/Condition, Power Assist, Park Brake, Anti-Lock Brake, Booster, Operation	
	10. Windshield Wipers & Washers - Operation, Park, Blades, Arm, Motor, Linkage Reservoir, Switch, Pump, Hose L R	
	11. AC, Heaters, Defrosters, External Dash Fan(s) - Operation, Shut-Off Valves, Controls, Speeds, Plumbing, Shielding, Diffusers, Ducts, Fasteners, Filter, Blades, Mounting	
	12. Dome & Step Well Lights - Operation, Lens, Switch, Mounting	
	13. Service Door - Operation, Control, Overhead Pad, Glass, Mounting, Seal	
	14. Horn(s) - Operation, Control, Location	
	15. Mirrors - Adjustment, Condition, Rearview, Convex, Interior, Mounting L R	
	16. Steering/Wheel -Play, Condition, Operation, Power, Tilt, Column, Mounting	
	17. Driver's Seat/Seat Belt - Operation, Condition, Cover, Mounting, Retractor	
	18. Passenger Seats - Frames, Mounting, Foam, Cuts, Bottoms, Backs, Flip-Up Seats, Barriers, Modesty Panels, Stanchions, Belts, C.S.R.S., Decals	
	19. Emergency Door(s)/Windows/Hatches - Operation, Buzzers, Labeling & Overhead Pad, Stop, Hold Open Mechanism, Instructions	
	20. Windshield, Side & Rear Windows - Cracks, Fogging, Latches, Visor	
	21. Child Reminder Alarm, 2-Way Radio - Location, Operation, Mounting, Wiring	
	22. Interior Wiring, Bulkhead Seals - Condition, Mounting/Routing, Openings, Electrical Panel, Fuses/Breakers	
	23. General Condition, Bus Interior - Trash Can, Floor, Grab Rail, Engine Cover, Paneling, Loose Objects, Trip Hazard, Molding, Graffiti, Sharp Edges, Screws, Dirty	
	24. Wheelchair Lift, Door, Securement System (If equipped) - Operation, Condition, Leaks, Lighting, Warning Light/Buzzer, Door Controls, Manual Operation, Chair Securement, Occupant Securement	
	B. OUTSIDE VEHICLE	
	1. Annual Inspection Certificate – Expired, Illegible, Peeling, Missing, Not Punched	
	2. Headlights, Turn Signals, Hazard, Side Marker, Brake, Tail, Backup Lights, Backup Alarm (if equipped), Clearance & ID Lights, Reflectors, Strobe Light (If Equipped) Park Lights, License Plate/Light(s), Reflectors, Rooftop Light (If equipped) -Operation, Condition, Lens, Type, Color, Mount, Aim, Switch, Flash, Missing, Guard, Legible, Cleanliness	
	3. Eight Light System - Operation, Condition, Color, Lens, Hood, Pilot, Type, Mount	
	4. Stop Arm(s), Student Crossing Arm, Child Safety Alarm (If equipped) -Operation, Condition, Bushing/Hinge, Leak, Mount, Decal, Blade, U-Bolt	
	5. Batteries – Condition, Type, Hold Down, Terminals, Cables, Clean, Paint, Tray	
	6. Electrical Compartment - Mounting, Routing, Connections, Wires, Fuses, Breakers	
	7. General Condition, Exterior - Mirrors, Bumpers, Body Damage, Paint, Grill Reflective Marking, Lettering, Emergency Door, Engine Hood, Brackets, Cleanliness	

Status Code: **No Mark** = Item OK **X** = Needs Repair **O** = Out of Service

Status Code	INSPECTION ITEMS	COMMENTS (Note Specific deficiencies)
	C. ENGINE COMPARTMENT	
	1. Fluid Levels - Condition, Brake, Power Steering, Oil, Transmission, Washer, Coolant, Leaks	
	2. Belts & Hoses - Tension, Condition, Routing, Alignment, Clamp, Type	
	3. Engine Performance - Starting, Shut Down, Stalls, Hesitation, Miss, Skip, Smoke	
	4. Components - Mounting, Condition, Power Steering, Brake, Water, Pump, Air Compressor & Filter, Fan/Clutch, Alternator, Master Cylinder, Booster, Hoses, Plumbing, Valves, Switches, Senders, Gauges, Lights, Turbo, Leaks Air Cleaner (Restriction _____ " H20),	
	5. Wiring – Routing, Condition, Securement, Type, Size, Connections, Harness, Loom	
	6. Fuel System - Condition, Operation, Securement, Connections, Leaks, Pump, Gov., Filter, Lines, Return Springs, Injectors, Carburetors, Linkage, Racor, Contamination, Throttle Valve	
	7. Radiator/Cooling -Mounting, Cap, Reservoir, Fan Shroud, After/Inter Cooler, P.S. Cooler, Shut-Off Valves, Plumbing, Leaks	
	D. UNDERNEATH BUS	
	1. Steering - Play, Column, Joints, Steering Gear, Leak, Pitman Arm, Drag Link, Steering Arm, Tie Rod & Ends, Idler Arm, Mounting, Alignment	
	2. Frame - Frame Rails, Cross Members, Modular Section, Condition, Securement, Alignment.	
	3. Front Suspension - Wheel Bearings, Hub, I-Beam, King Pins, Shackles, Spring Mounts, Pins & Bushings, A-Frames, Bushings, Ball Joints, U-Bolts, Shocks, Springs, Seals, Stabilizer, Air Bag, Control Valve, Ride Height L R	
	4. Brakes - Hoses, Lines, Chambers, Slack Adjusters, Pushrods, Linings, Drums, Rotors, Wheel Cylinders, Leaks, Valves, Reservoirs, Dryer, Calipers, Spring Chambers, Cage Bolt, Mounting, Brackets, Bleed Air, Hydrovac, Contamination.	
	Stroke: LF _____ RF _____ LR _____ RR _____ Lining: LF _____ RF _____ LR _____ RR _____	
	5. Mounts - Engine, Transmission, Starter, Condition, Securement, Alignment	
	6. Transmission - Bolts, Linkage, Lines, Filter, Cooler, Clutch, Adjustment, Bearing, Cylinder, Modulator, Leaks	
	7. Fluid Leaks - Oil, Coolant, Transmission, Power Steering	
	8. Fuel Tank - Leaks, Mounting, Hoses, Wiring, Cap, Vent, Barrier	
	9. Driveline - Shafts, U-Joints, Yokes, Hanger Bearings, Guards, Driveshaft Park Brake, Phasing, Damper, Mounting, Condition, Alignment	
	10. Rear Suspension - Axle Housing, Vent, Differential, Springs, U-Bolts, Shocks, Shackles, Spring Mounts, Control Arms, Pins, Bushings, Hangers, Seals, Wheel Bearings, Leaks, Stabilizer, Air Bag, Control Valve, Ride Height. L R	
	11. Body Securement & Structure - Mounts, Floor, Outriggers, Braces, Skirts, Condition, Securement, Alignment.	
	12. Exhaust Systems – ATDs, Condition, Leaks, Mounting, Muffler Tailpipe, Hangers, Clamps, Position, Extension, Catalytic Converter	
	13. Wheels And Tires – Type, Size, Tread Depth, Pressure, Damage, Matching, Alignment, Wheel Hardware LF RF LRO LRI RRO RRI	

Status Code	COMMENTS

Work Order Detail
CTF-2023-33



Asset ID:	5081267 2009 THMS 311TS	Station Location:	1301-CNHS - CENTRAL HIGH SCHOOL
Asset Number:	SAF-T-LINER-C2	Repair Location:	CTF - CHESTERFIELD SHOP
License Number:	140000016125	Job Status:	OPEN
Work Order ID:	SG91549	WO Meter 1:	0 MILES
Job Type:	CTF-2023-33	Projected Completion Date:	01/09/2023 02:22 PM
Job Type:	REPAIR	Priority:	1 - PRIORITY 1
WO Meter 2:	0 HOURS		
Title:	INSPECTION REPAIR		

Non Service Request Tasks		Warranty:
Task: N18-006 - Bottoms (Passenger Seats)		NO
WAC: 01 - ADJUST	Reason: 12 - EXTENDED REPAIR	
Work Class: 1 - SCHEDULED	Comments: Tighten R11 Seat Bottom.	
Task: N23-012 - Screws (General Condition)		NO
WAC: 01 - ADJUST	Reason: 12 - EXTENDED REPAIR	
Work Class: 1 - SCHEDULED	Comments: Add Screw To R9 Window Holder Plate.	
Task: S02-013 - Turn Signal (Road Lights And Reflectors)		NO
WAC: 03 - REPLACE NEW	Reason: 12 - EXTENDED REPAIR	
Work Class: 1 - SCHEDULED	Comments: Replace Left Rear Turn Signal..	
Task: T04-004 - Power Steering (Components)		NO
WAC: 01 - ADJUST	Reason: 12 - EXTENDED REPAIR	
Work Class: 1 - SCHEDULED	Comments: Tighten P/S Clamp On Hose At Bottom Of P/S Reservoir.	
Task: U04-002 - Hoses (Brakes)		NO
WAC: 01 - ADJUST	Reason: 12 - EXTENDED REPAIR	
Work Class: 1 - SCHEDULED	Comments: Add Rubber Hose To Right Side Brake Chamber Hoses.	
Task: U11-002 - Mounts (Body Securement And Structure)		NO
WAC: 01 - ADJUST	Reason: 12 - EXTENDED REPAIR	
Work Class: 1 - SCHEDULED	Comments: Tighten Body Clamp In Front Of The Rear End And Repaint.	

Overhead
 Small Parts - Labor: **0.00** Tools: **0.00** Total Overhead Costs: **0.00**
 Small Parts - Parts: **0.00** Overhead Costs: **0.00**

Comments:
 INSPECTION REPAIR

Internal Parts Cost:	
Internal Labor Cost:	
Commercial Parts Cost:	\$0.00
Commercial Labor Cost:	\$0.00
Commercial Misc Cost:	\$0.00
Commercial Tax & Markup:	\$0.00
Equipment Usage Costs:	\$0.00
Overhead Costs:	\$0.00
Internal Total:	\$0.00
Commercial Total:	0.00
Work Order Total:	\$0.00

SCDE
Vehicle Inspection Procedures
and
Repair/Out Of Service Criteria

Section 6
Inside of Vehicle

A. INSIDE 1. Stepwell/Grab Rails		
Inspection Procedures:	Repair if:	Out of Service if:
A. Stepwell 1) Check specification and condition of stepwell and tread.	Step tread is not secure or sealed at the inside edge where it meets next step. Stepwell tread ribbing is worn smooth less than four (4) inches in width when measured one inch (1") or more from the edge.	Step tread is not secure or sealed elsewhere on step. Any tripping hazards. Stepwell tread ribbing is worn smooth more than four (4) inches in width when measured one inch (1") or more from the edge. Sheet metal in stepwell is rusted through, has holes or structure has weakened and step(s) flex when weight is applied.
2) Inspect for presence of "NOTICE" decal(s) (Search and/or Video/Audio Monitoring).	Decal(s) are faded, torn, or defaced.	Decal(s) is missing or illegible.
B. Grab Rail(s) 1) Check for presence and secure mounting of entrance grab rail(s).		Handrail and/or any hardware is missing, damaged or has unauthorized modification. Mounting hardware is loose.
A. INSIDE 2. Emergency Equipment		
Inspection Procedures:	Repair if:	Out of Service if:
a. Fire Extinguisher: Check for presence of fire extinguisher and the following: 1) Check Manufacturer's Label		No fire extinguisher on bus Labeling is not legible to determine size and type

A. INSIDE		
2. Emergency Equipment (continued)		
Inspection Procedures:	Repair if:	Out of Service if:
a. Fire Extinguisher: (continued)		Rating is less than: 5.0 Lb.2A-10BC with hose except Type A Bus
2) Rating: check for proper U.L. (Underwriters Laboratory) rating.		
3) Pressure: check gauge		Pressure above or below green zone.
4) Mounting: check for accessibility and secure mounting.		Fire extinguisher not accessible to driver or not secured in mounting bracket. The bracket mount to the panel is loose.
5) Nozzle (If applicable), check for loose, obstructed, or damaged parts.		Nozzle or hose loose, missing, obstructed or excessive damage to any parts of extinguisher.
6) Safety Pin: check for presence of safety pin and tamper proof seal.	Seal is broken	The safety pin is missing. Tamper proof seal not of approved type. (ie. material cannot be broken easily)
b. First Aid Kit		
1) Check box and condition	Not labeled	Not present. Box not moisture and dust proof, won't seal, won't stay latched or contents inaccessible due to condition of box.
2) Check for presence of tamper proof seal.	Seal broken, inspect contents, replace.	Tamper proof seal not of approved type (i.e., material cannot be broken easily).
3) Mounting: Check accessibility and mounting of kit. It should be placed in the driver's area and easily accessible.	Loose mounting or loose bracket.	Not mounted or inaccessible

A. INSIDE		
2. Emergency Equipment (continued)		
Inspection Procedures:	Repair if:	Out of Service if:
b. First Aid Kit: (continued) 4) Contents: If the seal is broken, check that all contents are intact and sterile (for content list, see Chart 1).	Band-aids are missing or incomplete.	Contents are not individually sealed or sterile. Contents not of proper type or incomplete (except band-aids).
c. Body Fluid Cleanup Kit 1) Check kit and condition	Not labeled	Body Fluid Clean Up kit not present. Container not moisture and dust proof, won't seal, won't stay latched or contents inaccessible.
2) Check for presence of tamper proof seal.	Seal broken, inspect contents	Tamper proof seal not of approved type (i.e., material cannot be broken easily).
3) Check accessibility - Should be mounted in the driver's area and easily accessible.	Loose mounting or bracket.	Not easily accessible to driver/not secured.
4) Contents: If the seal is broken, check that all contents are intact and sterile (for contents list, see Chart 2).		Contents not of proper type, incomplete, or missing
d. Stop the Bleed Kit 1) Check mounting	Mounting hardware loose Securing strap frayed	Mounting hardware missing or damaged Securing strap broken/won't hold Buckle on securing strap broken/won't hold
2) Check Case and Condition	Missing Velcro Label	Not Present Zipper damaged Case damaged and will not hold contents
3) Check for Presence of Tamper Proof Seal	Seal missing or damaged	Tamper proof seal not approved type (i.e., material cannot be broken easily)
4) Contents: If the seal is broken, check that all contents are intact/present (for content list, see Chart 3)		Contents not of proper type, incomplete, or missing.

e. Reflectors 1) Check for proper type and condition of emergency roadside reflectors.	Bus manufactured after 1992 is not equipped with self-standing, triangular, 17" tall reflectors. Any of the reflectors are broken, deformed or unusable.	
2) Check quantity: three (3) required.	Fewer than three (3) reflectors are present.	

A. INSIDE
2. Emergency Equipment (continued)

Inspection Procedures:	Repair if:	Out of Service if:
3) Check accessibility, mounting and condition of box. Must be securely mounted in the driver's area.	Storage box broken or won't remain latched. Box is not accessible or not securely mounted forward of passenger compartment.	
4) Check for presence of tamper proof seal.	Seal broken, inspect contents, Tamper proof seal not of approved type (i.e., material cannot be broken easily).	
f. Webbing Cutter 1) Check for presence of a durable webbing cutter securely mounted in the driver's compartment and within easy reach of the driver when in the seated position.		No durable webbing cutter is present. The webbing cutter is not securely mounted in the driver's compartment within easy reach of the driver.
g. Emergency Safety Blanket 1) Check for proper location and mounting of Emergency Safety Blankets. Required on all Special Needs buses.	The blanket is not properly mounted or not mounted in an approved location for bus type.	
	The blanket is not properly folded and stored in pouch.	

FIRST AID KIT & BODY FLUID KIT SUPPLY CHART

Chart 1: FIRST AID KIT	
DESCRIPTION	QUANTITY
1" bandage compress (e.g., Band-Aid)	2 pkgs.
40" triangular bandage with 2 safety pins	1 pkg.
4" X 4" sterile gauze pads	6 pkgs. -2 each
2" rolled Gauze bandage 6 ft. in length	2 pkg.
1" roll adhesive tape 2 1/2 yards in length	1 roll
Eye dressing packet	2 pkgs.

CHART 2: BODY FLUID CLEANUP KIT	
DESCRIPTION	QUANTITY
An EPA registered germicide (tuberculocidal) disinfectant	1
A fully disposable wiping cloth	1
A water-resistant spatula	1
Step-by-step directions	1
Absorbent material with odor counteractant	1
Protective gloves	2 pairs
Towelettes	1 pkg.

Chart 3: STOP THE BLEED KIT	QTY
Tourniquet	1
Medical Scissors	1
Latex Gloves	1 pr.
Marker, Black	1
Compressed Gauze	2
Trauma Bandage	1
Instructions	1

A discard bag (non-labeled paper bag with plastic liner and twist tie). This bag shall be approximately 4" x 6" x 14" and be of a non-safety color (i.e. not red, orange, or yellow).	1
---	---

A. INSIDE		
3. Registration, Insurance Card		
Inspection Procedures:	Repair if:	Out of Service if:
a. Registration 1) Check for a valid SC registration certificate in a mounted transparent holder.	Registration certificate is not on the bus, is invalid, not legible or holder missing.	
b. Insurance Card 1) Check for presence of insurance card in a mounted transparent holder.	Insurance Card is not on the bus, is invalid, not legible or holder missing.	
A. INSIDE		
4. Shifter, Transmission		
a. Shifter-Automatic Transmission 1) Check that shifter operates easily. 1b) Touch-Pad operation	Does not shift easily into all gears.	Will not shift into all gear positions. Any loose or missing hardware securing the shifter, cable or linkage.
2) Correctly indicates the gear that the transmission is in. 2b) LED correctly indicates the gear that the transmission is in.	Misaligned, but indicates correct gear. Some of LED's are out but can still determine which gear it's in.	Indicates the wrong gear. L.E.Ds are out and/or can't tell which gear the transmission is in.
3) Has a functional detent mechanism with a knob or handle on end of shift lever.		Detent is non-functional. Knob or handle is missing from end of shifter lever.

3b) Check Markings on touchpad.		Loose knob or handle. Buttons on touch-pad unreadable.
b. Shifter-Manual Transmission 1) Check that shifter operates easily.	Does not shift easily into all gears.	Will not shift into all gears. Hangs between gears.
2) Condition of lever and knob.	Bent lever or knob cracked. Loose knob. Pattern worn off knob.	Lever not securely attached. Knob missing or indicates wrong pattern.
c. Neutral Safety Switch 1) Check to determine if has a functional neutral safety switch that will allow the starter to operate only in park or neutral.		The starter will engage in any gear other than park or neutral.
A. INSIDE 5. Dash Decals		
Inspection Procedures:	Repair if:	Out of Service if:
a. Check for Children Left on Bus	If the decal is missing or not legible on any bus.	
b. Do not move the bus with the lift down	If decal is missing or not legible.	
c. Cross view mirrors are for pedestrians, vehicles may not appear properly	If decal is missing or not legible.	
d. ABS Brakes	If decal is missing or not legible.	
e. Engine Regeneration, 2007 and above certified	If decal is missing or not legible.	
f. Brake Interlock 1999 and newer		If decal is missing or not legible
g. Do not operate if the backup alarm does not work.		If decal is missing or not legible (1995 and later buses).

A. INSIDE		
6. Engine Controls		
Inspection Procedures:	Repair if:	Out of Service if:
a. Ignition Switch: 1) Check that switch only operates by key.		Key sticks in switch. The switch operates without a key.
2) Should be mounted securely in OEM location.	Loose	Not mounted in OEM location.
3) Should operate freely in each function (i.e., start, run, off, and accessory position).		Engine will not crank or start. Switch sticks in any position. Doesn't function properly in start, run, off, or accessory position or is intermittent in any position.
b. Accelerator 1) Check that accelerator pedal, control design, condition, and mounting securement are OEM.	Pedal cover (as originally equipped) is worn through or smooth in any area	Pedal and assembly not mounted securely. Pedal, control design, and mounting not OEM.
2) Inspect pedal assembly and linkage for loose or missing hardware.		Loose or missing hardware.
2) Inspect pedal assembly for air leaks if applicable		Evidence of air leakage
3) Check for smooth operation of pedal assembly and linkage in the accelerating and coast position.		Accelerator control and linkage sticks or doesn't operate freely.
4) Inspect for unauthorized modifications to pedal (i.e., extensions or other devices attached to pedal).		Pedal built up with extender or block(s), or not of OEM design.
c. Engine Shutdown 1) Only O.E.M. approved ignition-controlled shutdown acceptable on all vehicles.		Not OEM or OEM approved.
2) Check for free operation of shutdown over full range with minimum effort (if equipped with manual type shutdown on diesel buses.	The cable is sticking or hard to operate.	The engine can be started, in shut down position, or it does not stop engine.

A. INSIDE 6. Engine Controls		
Inspection Procedures:	Repair if:	Out of Service if:
d. Fast Idle Switch 1) Check operation of switch.	Switch On and does not engage.	Switch Off and does not disengage fast idle.
A. INSIDE 7. Gauges, Indicators & Dash Lights, Engine Warning Lights, and Buzzers		
Inspection Procedures:	Repair if:	Out of Service if:
a. Gauges: Check from driver's position the visibility, OEM location, readability, operation, accuracy, and condition of the following gauges and warnings:		
1) Speedometer and odometer		Speedometer is known not to work or is confirmed to be inaccurate - Speedometer is unreadable or damaged. Odometer doesn't work or is not working properly - Odometer is unreadable.
2) Oil pressure. 3) Temperature. 4) Fuel. 5) Voltmeter 6) HV Battery State of Charge	Oil pressure, temperature, fuel, voltmeter, or ammeter gauge are inaccurate, damaged, or difficult to read.	Oil or temperature gauge does not function or is unreadable. Oil pressure gauge or tube leaks. High Voltage State of Charge gauge inoperative
6) Air pressure		Air pressure gauge(s) are known to be inaccurate, are unreadable or not working.
7) Tachometer (if equipped)	Inoperative	

A. INSIDE		
7. Gauges, Indicators & Dash Lights, Engine Warning Lights, and Buzzers		
Inspection Procedures:	Repair if:	Out of Service if:
8) Hour meter (if equipped)	Inoperative	
9) Transmission Temperature Gauge (if equipped)	Inoperative	
b. Indicators, Dash Lights: Check for the presence and operation of the following indicators:	Light bulb for the following gauge or indicators is inoperative:	Light bulb for the following gauge or indicators is inoperative:
1) Low air pressure		Low air pressure
2) High beam indicator light.	High beam indicator.	
3) Left and right turn signal and 4-way hazard.	Left or right turn signal or 4-way hazard.	
4) Check all dash and control panel lights for illumination at gauges and switches.	Oil pressure Temperature Fuel Voltmeter Ammeter Shift Indicator light is inoperative. One or more lights for control switches are inoperative. One or more panel lights are inoperative.	All dash or control panel lights are inoperative. Speedometer lights are inoperative.

A. INSIDE		
7. Gauges, Indicators & Dash Lights, Engine Warning Lights, and Buzzers (continued)		
Inspection Procedures:	Repair if:	Out of Service if:
c. Engine Warning Lights and Buzzer: Check for the presence and operation of the following warning lights and buzzers on all buses.		
1) Stop Engine Light and Buzzer		Warning light or buzzer does not operate as designed.
2) Low oil pressure dash warning light and buzzer. (If equipped)		Low oil pressure dash warning light or buzzer is inoperative.
3) High Exhaust Temperature Indicator		High Exhaust Temperature dash warning light is inoperative.
4) Exhaust Regeneration Light		Engine Regeneration dash warning light is inoperative, or lamp is on.
5) ABS Warning Light	Lamp is on	ABS dash warning light is inoperative.
6) Low Coolant Level Light		Low Coolant Level dash warning light is inoperative, or lamp is on.
7) Malfunction Indicator Lamp (MIL)		Vehicle is placed OOS until DTC code is verified not to be causing imminent danger or possible engine damage. The lamp is inoperative.
8) Check Engine Lamp		Vehicle is placed OOS until DTC code is verified not to be causing imminent danger or possible engine damage. The lamp is inoperative.
9) Engine Compartment High Heat Alarm and Buzzer (RE buses)	High Heat dash warning light is inoperative. (Green)	High Heat dash warning light and or buzzer is on (Red) Red lamp or buzzer is inoperative.

10) DEF Malfunction Lamp		If lamp is on
A. INSIDE 8. Air Brake System:	NOTE: If vehicle is equipped with Anti-Lock Braking System, refer to appropriate manufacturer's service manual for inspection criteria.	
a. Gauge(s): 1) For vehicles equipped with air brakes check for presence of two (2) air pressure gauges (or single gauge with dual needles). One (1) gauge or needle should indicate air pressure available to the primary and one (1) to the secondary brake system.		Any gauge is missing or cannot be read. Gauge is not accurate. Any gauge is not in OEM location. More than a 15-psi difference in dual air brake system (dual gauges)

A. INSIDE 8. Air Brake System: (continued)		
Inspection Procedures:	Repair if:	Out of Service if:
b. Park Brake: Check for proper operation and adjustment of park brake as follows: 1) With vehicle stopped, apply park brake. When engine torque is applied by placing transmission selector in "Drive" and "Reverse" (automatic transmission) and accelerating the engine to a fast idle (approximately 1,200 RPM), vehicle should not move.		Vehicle moves after speeding up the engine (transmission in gear) with park brake applied.
2) Check PP-1 (pop-off style) emergency brake control valve. Check condition, location, mounting, and type of valve and knob. With pressure above 45 psi, apply and release valve to check operation.		Valve not mounted securely (in original position) Missing knob or lever. Knob is broken, cracked or instructions unreadable or not approved type. Inoperative or leaking

4) Check (PP-1) park brake control valve for emergency activation of valve by pumping down brakes (starting with at least 60 psi in air system) and noting air pressure at which valve “pops out”.		Park brake pop-off valve fails to “pop out” between 15 to 50 psi
5) Intellipark park brake system: Check operation, LED indicators, and warning buzzer.	If one LED indicator is operative	Both LED Indicators are inoperative Warning buzzer inoperative Improper Operation
c. Low Air Warning: Check operation of low air warning buzzer and light.		
1) With ignition key switch in run position (engine off), pump air brake pedal to drop air pressure. Low air warning buzzer and light should activate at approximately 55 - 60 psi.		Light or buzzer is inoperative. Light or buzzer fails to operate by 50 psi.

A. INSIDE		
8. Air Brake System (continued)		
Inspection Procedures:	Repair if:	Out of Service if:
2) Start the engine and build up air pressure. Warning buzzer and light should deactivate by 70 psi.		Continues to operate above 70 psi.
d. Pedal 1) Check air brake pedal assembly for adjustment, mounting, condition, operation, and rubber cover pad (if originally equipped). Check for presence of prohibited extender block.	Rubber cover pad is worn through or is worn smooth in any area.	Rubber cover pad is missing (if originally equipped). Any part of pedal and assembly is damaged, loose, missing, or has been modified. Pedal is equipped with any type of extender block.

A. INSIDE		
9. Hydraulic Brakes		
Inspection Procedures:	Repair if:	Out of Service if:
a. Standard Vacuum Assisted Hydraulic Brakes; Inspect for:		
1) Any visible leaks in the hydraulic brake system.		Any leaks are found.
2) Check brake pedal reserve (distance from floor) upon firm brake application (engine running).		Brake pedal (reserve) is less than one (1") inch from floor.
3) Check brake pedal fade (pedal falls to floor when held down with engine running or with engine off) indicating brake system leak.		There is any brake pedal fade.
4) Check for brake warning light illumination with ignition key in "Start" position.		Brake failure warning light does not light when key is moved to the start position. Brake failure
5.) Check to ensure brake failure warning light is not on during normal operation (with or without brakes applied).		warning light comes on (or stays on) during normal operation (with or without brakes applied).

A. INSIDE		
9. Hydraulic Brakes(continued)		
Inspection Procedures:	Repair if:	Out of Service if:
a. Standard Vacuum Assisted Hydraulic Brakes; Inspect for: (continued) 7) Check vacuum assist (booster) operation. With the engine off apply brakes several times to exhaust vacuum. Depress and hold the brake pedal down while starting the engine. Pedal should “fall away” slightly, indicating increased pressure being applied by the assist unit.		Vacuum assist system malfunctions (pedal does not “fall away” slightly when engine is started).
8) Turn the engine off and apply the brakes. There should be enough reserve in the vacuum system to allow at least one (1) power-assisted brake application.		Vacuum reserve is insufficient to allow at least one (1) brake application.
9) Check all brake hardware components inside bus for secure mounting, routing, and condition, including: a) Pushrod and clevis assembly.		Brake pedal assembly, pushrod, and clevis, or emergency brake control assembly is not securely mounted, has loose, missing or worn hardware or is damaged.
b) Brake pedal assembly and rubber cover		Rubber pedal cover is missing, worn smooth or worn through. Pedal is equipped with any type of “extender block.”
c) Emergency brake control assembly.		Emergency brake control is hard to operate or doesn’t latch and release properly.

A. INSIDE		
9. Hydraulic Brakes (continued)		
Inspection Procedures:	Repair if:	Out of Service if:
a. Standard Vacuum Assisted Hydraulic Brakes; Inspect for: (continued) 10) Parking Brake Operation: With vehicle stopped (engine running), apply park brake. When engine torque is applied or by placing transmission selector in gear (automatic transmission) and accelerating the engine to a fast idle (approximately 1,200 RPM), vehicle should not move forward.		The park brake doesn't hold or function properly. Adjustment is needed (lever type with adjustment knob). Repair prior to leaving vehicle.

A. INSIDE		
9. Hydraulic Brakes (continued)		
Inspection Procedures:	Repair if:	Out of Service if:
b. Hydraulic Power Assisted Hydraulic Brakes with electric pump backup and driveshaft park brake system, Inspect for: 1) Any visible leaks in the brake or hydraulic assist system.	(Continued on Next Page)	Any leaks are found in the brake or hydraulic assist system.

2) Check brake warning and backup systems using the appropriate chassis manufacturer's procedure in Chart.		The brake system does not pass the entire test in the appropriate chart.
3) Check brake pedal reserve (distance from floor) upon one (1) firm brake application (engine off, hydraulic boost depleted).		Brake pedal (reserve) is less than one (1) inch from floor.
4) Check brake pedal fade (continues to fall to floor after initial firm application) with engine off.		There is any brake pedal fade (falling away) after initial firm application.

A. INSIDE		
9. Hydraulic Brakes (continued)		
Inspection Procedures:	Repair if:	Out of Service if:
c. Hydraulic Power Assisted Hydraulic Brakes with electric pump backup and driveshaft park brake system, inspect for: (continued) 5) Check all brake hardware components inside the bus for secure mounting, routing, and condition, including: a) Pushrod and clevis assembly. b) Brake pedal assembly and rubber cover pad (if originally equipped). c) Emergency brake control assembly.	Rubber cover pad is worn through or worn smooth in any area.	Brake pedal assembly, pushrod, and clevis, or emergency brake control assembly is insecurely mounted, has loose, missing, or worn hardware, or is damaged. Rubber pedal cover pad is missing (if originally equipped) or worn out. Pedal is equipped with any type of "extender block". Emergency brake control is hard to operate or doesn't latch and release properly.
6) Check Parking Brake: With vehicle stopped (engine running), apply park brake. When engine torque is applied by partially engaging clutch in second gear and reverse (manual	(Continued on Next Page)	Emergency brake control is hard to operate or doesn't latch and release properly.

<p>transmission) or by placing transmission selector in “Drive” and “Reverse” (automatic transmission) and accelerating the engine to a fast idle (approximately 1,200 R.P.M.), vehicle should not move.</p>		<p>Adjustment is needed, (lever type with adjustment knob on it) do so now.</p> <p>Park brake doesn't hold or function properly</p>
--	--	---

A. INSIDE		
10. Windshield Wipers & Washers		
Inspection Procedures:	Repair if:	Out of Service if:
a. Operation: Inspect both wipers for: 1) Swept area field of view.	Wiper goes past perimeter of glass.	Either wiper does not effectively clear the driver's field of vision.
2) Proper operation of both wipers on high, low and/or intermittent speeds and condition and mounting of switch(es) and knob(s).	Either wiper does not operate on low or intermittent speed. Switch(es) mounting loose or knob(s) loose.	Either wiper does not operate properly at high speed. Knob(s) missing
3) Condition and mounting of wiper motor and linkage.	Either wiper motor or linkage is visibly damaged or loose.	
4) Inspect for proper washer operation.	The washer does not operate or is improperly adjusted or out of fluid.	
b. Park: 1) Inspect for parked position of wipers when turned off.		Either wiper does not automatically return to parked position out of driver's line of sight when turned off.
c. Blades: 1) Inspect blades for condition, mounting, and tension.		Either blade is damaged, deteriorated, loose, or does not hold proper tension against windshield.

A. INSIDE		
11. HVAC SYSTEM		
Inspection Procedures:	Repair if:	Out of Service if:
a. Heaters Inspect heater system for:		
1) Heating performance and water control valve (interior).	Not producing adequate heat. Water control valves are hard to operate.	
2) Blower operation, condition, and control switches.	Heater blowers do not work on any speeds, are noisy, or vibrate. Blower switches are damaged, loose, or blower operates intermittently.	
3) System / hose leakage, condition, and hose shielding (shielding required for exposed hoses on interior of all buses).		Heater cores, hoses, or valves have visible leakage. Heater hoses are cracked, swollen or badly chafed - Shielding is missing or does not completely cover hoses.
4) Condition of ductwork and heater box.	Heater ductwork or heater box components are missing, damaged, loose, or obstructed	Any portion of heating system within passenger area creates sharp edges, projections, or other hazards to passengers or driver.
b. Defrosters Inspect windshield defroster system for:		
1) Airflow, heat, and coverage area.		Airflow is not present at all defroster outlets.
2) Blower operation, condition, and control switches.	Any defroster blower does not work on low speed, is noisy, or vibrates. Blower switches are damaged or loose.	Any defroster blower does not work on high speed.
3) Condition of ductwork, diffusers, and fresh air control (if equipped).	Any ductwork or diffusers are loose or damaged. Fresh air control (if equipped) does not function.	Any diffuser missing.

A. INSIDE 11. Heaters, Defrosters, Aux. Fan(s) (continued)		
Inspection Procedures:	Repair if:	Out of Service if:
C. Driver Auxiliary Fan(s) Inspect auxiliary fans (If equipped) for: 1) Presence of fan, mounting and condition.	Fan is not present. Fan mounting is loose, or fan won't stay in adjustment.	Fan not OEM or SCDE approved. (i.e. plastic blade).
2) Blade condition.	The fan blade is damaged.	
3) Protective cage mounting and condition.	Protective cage is loose or damaged	The protective cage is missing.
4) Operation and switch	Fan does not operate, one (1) speed does not function, fan is noisy or vibrates. The switch is loose or damaged.	
A. INSIDE 12. Dome and Stepwell Lights		
a. Operation and condition: 1) Check dome and stepwell lights for condition and operation. 2) Check landing light under stepwell (if equipped)	Any lens is cracked, broken, or dirty. Any dome light is out. Stepwell light is on when door is closed. Switch mounting is loose, or knob is missing. Stepwell landing lights inoperative	Loose lens or fixture. The lens is broken so that light or fixture is exposed. Dome lights are not functioning, or 50% or more lights are out. Stepwell light is not functioning. Stepwell light does not activate when headlights are on, and door is open with ignition switch "ON".

A. INSIDE 13. Service Door		
Inspection Procedures:	Repair if:	Out of Service if:
a. Operation 1) Check service door assembly for operation, adjustment, condition, mounting, and fit.	Door does not seal properly, or seals are damaged, ripped, or deteriorated. 3 to 6-inch line crack in glass	Door jams, binds, or is difficult to close or open. Door assembly is damaged, or mounting is loose so as to affect opening/closing. Glass has been replaced with Plexiglas, is broken, or has a line crack more than 6 inches. Door glass is fogged more than one (1) inch in from border, or visibility through glass is poor. Door is equipped with any lock except factory approved system. Door seals are not present. Door will not open or close completely
2) Check door hinge and hinge screws	Hinge screws loose.	Hinge or pin condition interfering with operation of door.
b. Control 1) Check manual service door control and rod assembly for over-center or latching device, condition, mounting, and operation.	Control, rod hardware, or mounting is loose. Door control doesn't operate freely.	Manual control will not lock over-center, or latching mechanism is inoperative. Door control requires excessive force to operate.

A. INSIDE 13. Service Door (continued)		
Inspection Procedures:	Repair if:	Out of Service if:
b. Control (Continued) 2) Check air powered service door control assembly for leaks, operation, insecure door in closed position, and emergency release.	Air powered system leaks.	Air door emergency release does not function, or control is broken. The air door does not function properly, or at all.
c. Overhead Pad 1) Check bus for pad that is a minimum three (3) inches wide, high density foam rubber padded safety cushion, mounted directly above the inside of the service door.	Pad is loose, or cover is torn.	Pad is missing or wood is exposed.
A. INSIDE 14. Horn(s)		
a. Horn operation and condition 1) Check for operation of horn(s) and for location and condition of horn switch.		Horn(s) does not operate properly or at all. Horn button is not mounted in the original OEM location. Horn button sticks, or horn button operates intermittently such as when steering wheel is rotated.

A. INSIDE		
15. Mirrors		
Inspection Procedures:	Repair if:	Out of Service if:
<p>a. Rear-view:</p> <p>1) Check rearview mirror for specifications, condition, mounting, and adjustment.</p> <p style="text-align: center;">SEE CHART</p>		<p>Any exterior rearview mirror is broken, cracked, or loose in the frame.</p> <p>Either mirror does not give driver a clear view down to lower outside edge of rear tire at ground level, on both sides to the rear.</p> <p>Any bracket is broken, or mirror mounting is insecure.</p> <p>Reflective surface is deteriorated.</p> <p>Any bus does not have the same mirror system on each side.</p>
<p>b. Convex:</p> <p>1) Check convex crosswalk and side-view mirrors for specifications (correct type, size, and location) condition, mounting, and adjustment.</p> <p style="text-align: center;">SEE CHART</p>		<p>Required convex mirrors are not present (see chart).</p> <p>Any mirror is cracked, broken, or loose in frame.</p> <p>Any mirror is out of adjustment.</p>

A. INSIDE 15. Mirrors		
Inspection Procedures:	Repair if:	Out of Service if:
b. Convex / Crossview: (continued)	Crossview mirror lights are inoperative (if equipment)	Any mirror reflective surface is deteriorated. Any portion of mirror mounting system is loose or broken. Mirrors do not give the driver a clear view of the area around the front of the bus.
c. Interior: 1) Check interior rearview mirror for size, condition and mounting. 2) Check operation of back-up camera (if equipped) <u>Type A buses</u> All years - minimum 50 square inches <u>Type C & D buses</u> 2005 and later – minimum 6” X 24” convex glass	Back-up camera inoperative or improperly adjusted	Mirror does not meet minimum size/design requirements. Mirror does not have rounded corners and protected edges. Any portion of reflective surface is obstructed by sun visor, stickers, or other items or is deteriorated. The driver’s view of images in mirror is not clear due to distortion or other causes. Mirror mounting is loose.

FMVSS.111 MIRROR ADJUSTMENT

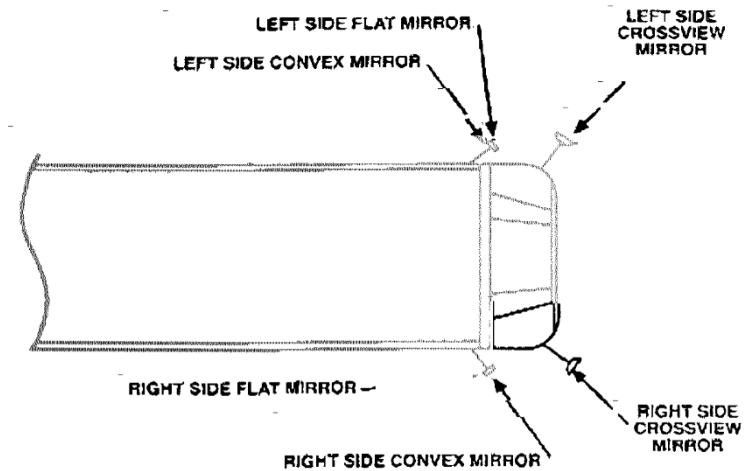
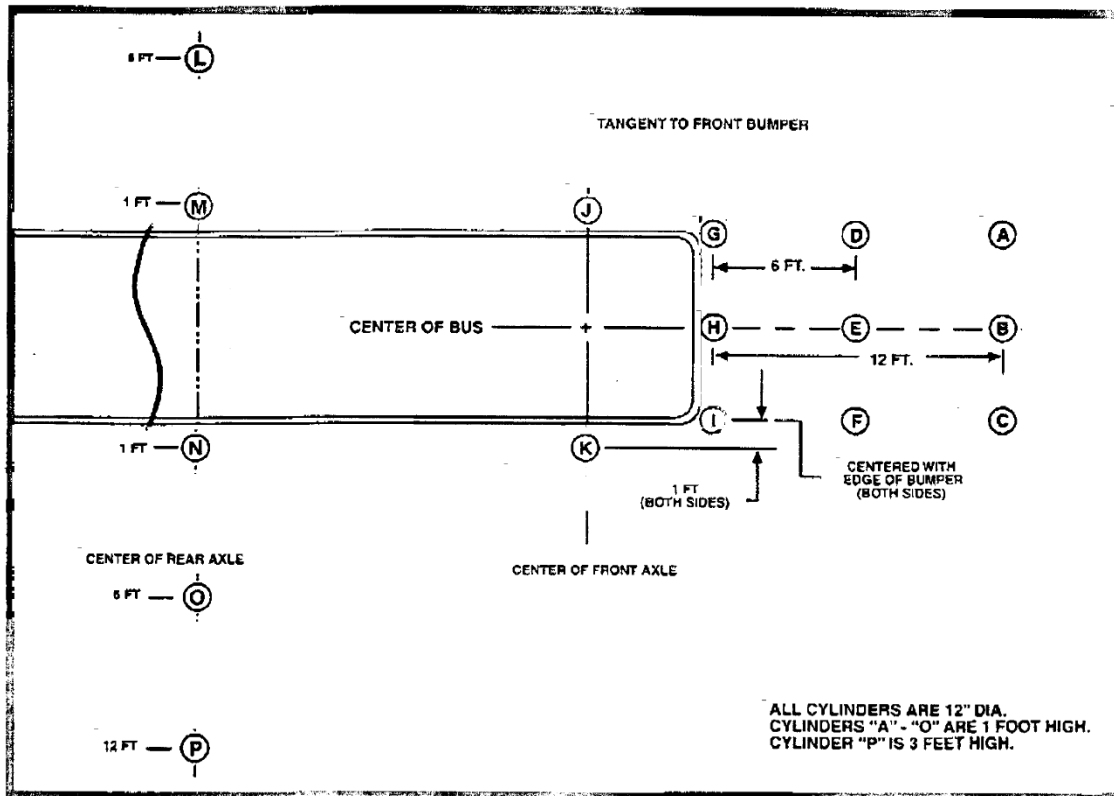

REAR VIEW MIRRORS (SYSTEM A) Used together, the left side flat mirror and the left side convex mirror must provide a view of cylinder “M” and, continuing from there, 200 feet rearward of the mirror surface. Used together, the right-side flat mirror and the right-side convex mirror must provide a view of cylinder “N” and, continuing from there, 200 feet rearward of the mirror surface.

CROSSVIEW MIRRORS (SYSTEM B) Any cylinders “A-P” can be viewed using either of the crossview mirrors, but all must be visible. Only those cylinders that the driver can view by direct vision and are forward of the front bumper may be excluded.

A. INSIDE 16. Steering		
Inspection Procedures:	Repair if:	Out of Service if:
a. Play: Check for play in the steering system, at the steering wheel, using the following procedures: 1) Visual check - from inside bus with engine running, rotate steering wheel lightly from side to side until the turning motion can be observed at tires and note free play (lash) at steering wheel outer diameter. This procedure must be performed with the vehicle on the ground.		Free play (lash) exceeds amounts specified in Chart.
2) To check power assist operation run engine at fast idle and turn steering wheel a full right and left turn and feel for binding, jamming, or belt slippage.		Power assist is inadequate, or there is binding, jamming, or belt slippage.
3) Visually check the condition of steering wheel.	The steering wheel plastic is cracked.	The steering wheel is loose on column. The steering wheel is non-OEM design. Plastic is missing so that metal steering wheel reinforcement is exposed. Any portion of the metal steering wheel components are cracked or broken.
b. Column: 1) Check steering column inside bus for up and downplay (parallel to shaft), side to side play (perpendicular to shaft), and for proper mounting.		Side to side play in steering column exceeds 1/4 inch or up and downplay exceeds 1 inch. Column assembly mounting (including floor mounting plate) or fasteners are loose. Rubber boot at bulkhead (if equipped) is torn, ripped, or missing.
2) Check operation of tilt and telescoping functions (if equipped).	Does not tilt or telescope.	Does not latch securely in place.

CHART

STEERING WHEEL PLAY (LASH) MEASUREMENTS

Lash shall not exceed the following measurements.

Steering Wheel Size	Play (Lash) Manual Steering	Play (Lash) Power Steering
16 inches or less	2 inches	4 1/2 inches
18 inches	2 1/4 inches	4 3/4 inches
20 inches	2 1/2 inches	5 1/4 inches
22 inches	2 3/4 inches	5 3/4 inches

A. INSIDE 17. Driver's Seat and Belt		
Inspection Procedures:	Repair if:	Out of Service if:
a. Seat and Belt 1) Check driver's seat and belt for specifications (type and adjustability), condition, mounting, and operation.	Seat adjustment binds or is difficult to operate. Seat adjustment is loose, or adjustment hardware is missing. Seat upholstery or foam is deteriorated or damaged. Seat upholstery is wrong type (vinyl/cloth). Seat belt retractor covers, or belt covers are damaged or loose.	The driver's seat will not adjust as designed. Seat mounting /bottom is unstable, loose, or seat mounting hardware is missing. Driver's seat belt is missing or not an approved type. Seat frames are exposed due to deterioration of upholstery or foam. Mounting retractors or belt guides are not secure. Seat belt webbing or stitching is frayed or damaged. The seat belt is routed improperly. The seat belt does not extend or retract freely. Seat belt buckle and tongue assembly does not latch or release properly. Extenders have been added to belt or belt mounting.

A. INSIDE		
18. Passenger Seats		
Inspection Procedures:	Repair if:	Out of Service if:
a. Frames: 1) Inspect passenger seat frames for condition of welds, tubing, and hardware.		Seat frames or welds are broken or cracked. Any seat back frame is repaired using non-OEM hardware. Any seat frame hardware has been added or modified to result in projections or sharp edges
2) Check for the presence of non-O.E.M. seat frames.		There are any non-OEM seat frames installed.
3) Check for presence and condition of passenger restraining belts on Special Needs (1988 models have ALR retractors) buses and Type "A" buses		Restraining belts are non-functional.
b. Mounting: 1) Inspect the condition of passenger seat mounting.		The seat mounting at floor or seat rail is loose. Seat mounting fasteners are of lower grade or different type than OEM fasteners for the specific locations.

A. INSIDE		
18. Passenger Seats (continued)		
Inspection Procedures:	Repair if:	Out of Service if:
<p>c. Pads/Safety Barriers:</p> <p>1) Inspect seat back/barrier foam for specifications and condition.</p>		<p>Seat back padding is of wrong type for specific year model bus:</p> <p>The original thickness or density of any seat back foam around frame has been significantly reduced due to wear, deterioration, or other factors.</p> <p>Foam envelope is split, delaminated, or there is no padding between any portion of seat back frame and covering.</p> <p>Any bus does not have a padded safety barrier in front of any passenger seat that does not have another seat in front of it.</p>
<p>d. Cuts/Upholstery Damage.</p> <p>1) Inspect seat and safety barrier upholstery for condition and specifications.</p>	<p>Seat upholstery is cut, torn, or ripped.</p> <p>The seat upholstery is not repaired properly.</p> <p>Any upholstery has been replaced with non-OEM type material.</p>	<p>Seat upholstery is missing.</p>

A. INSIDE 18. Passenger Seats (continued)		
Inspection Procedures:	Repair if:	Out of Service if:
e. Bottoms 1) Inspect seat bottoms for securement and condition.		Any seat bottom padding or cushion has significant deterioration or damage. Any seat bottom is not securely anchored to the seat frame. Any seat bottom has a protruding edge or plywood is broken.
f. Modesty Panels and Stanchions: 1) Inspect modesty panels and stanchions for condition, specifications, mounting, and padding (as required).	Stanchion or modesty panel mounting is loose (Special Needs buses). Stanchion padding is missing or is damaged so that metal is exposed.	
g. Optional Infant/Toddler Seating: 1) Check condition of child restraint and operation of system.		The seat does not operate or function properly according to the manufacturer's operational procedures. Any damage to belt webbing and latch Missing pad, cover or foam
h. Flip-Up Seats: 1) Check condition and operation of flip-up seats		The seat does not automatically return to an upright position when not in use. Any sharp edges lose or protruding hardware that could injure or snag passengers. Seat or hardware malfunction that could trap arm or leg between seat or back.

h. Flip-Up Seats: Check retention cable (if equipped)	If cable is frayed or shows signs of damage	If the cable is broken
--	---	------------------------

A. INSIDE 19. Emergency Door/Windows/Hatches		
Inspection Procedures:	Repair if:	Out of Service if:
<p>a. Emergency Door:</p> <p>1) Inspect for operation and condition of emergency doors, door latch, door hold open feature (if equipped), and door seal.</p> <p>Note: Emergency door(s) 1992 and later must be equipped with a self-canceling device to hold the door open during use.</p>	<p>Door handle, latch, or mounting hardware is loose.</p> <p>Mounting of guard for inside rear door handle is loose.</p> <p>Side emergency door seal damaged or does not effectively prevent water, and/or dirt from entering bus.</p> <p>Cover or padding on bar over door torn or damaged and wooden base not exposed.</p>	<p>Any emergency door latch does not operate smoothly and easily when closing or opening the door. (Latch mechanism requires more than 40 pounds of pressure to release.)</p> <p>The door does not open at least 90 degrees. Inside door handle is not equipped with a guard</p> <p>Any emergency door is equipped with any type of locking device.</p> <p>Hold open device (if equipped) is non-operational, bent, damaged or loose.</p> <p>Rear emergency door seal damaged or does not effectively prevent exhaust, water, and/or dirt from entering bus.</p> <p>Padded bar over door missing or damaged to expose wood base.</p> <p>Emergency door exit not properly labeled.</p>
<p>b. Push out windows:</p> <p>1) Check condition and operation of push out windows (if equipped).</p>		<p>Emergency window latch does not latch window securely or window does not open easily.</p>
<p>c. Roof hatches</p> <p>1) Check operation of roof hatches (if equipped).</p> <p>(Continued on Next Page)</p>	<p>The roof hatch seal is damaged or dislodged.</p> <p>The roof hatch does not open to ventilation position.</p>	<p>The roof hatch does not open easily to full “emergency open” position from the inside or the outside.</p>

<p>d. Buzzers</p> <p>1) Check operation of buzzers for emergency doors, emergency exit windows, and roof hatches</p>	<p>Buzzer gives false alarms.</p>	<p>Buzzer system for any emergency door, exit window, or any roof hatch does not function or is not audible at driver's location.</p>
---	-----------------------------------	---

A. INSIDE
19. Emergency Door/Windows/Hatches
(continued)

Inspection Procedures:	Repair if:	Out of Service if:
<p>f. Labeling and Pad</p> <p>1) Inspect label and opening instructions for emergency door, emergency windows, and emergency exit/ventilator (roof hatch).</p>	<p>Any emergency exit does not have legible instructions for operation on the inside of the exit.</p>	<p>Emergency exits are not clearly labeled inside the bus as "Emergency Door" or "Emergency Exit".</p>
<p>2) Inspect emergency door header pad.</p>	<p>Pad cover is torn.</p>	<p>Pad is loose, missing or wood is exposed</p>

A. INSIDE
20. Windshield, Side & Rear Windows

<p>a. Glass Cracks</p> <p>1) Inspect the windshield and all windows for cracks and other damage.</p>		<p>There are any cracks in the windshield in the driver's direct field of vision (area swept by wiper) greater than six (6) inches in length or any star cracks greater than two (2) inches in diameter.</p> <p>There is any crack in the windshield or any window greater than twelve (12) inches in length.</p> <p>There is any glass missing.</p> <p>There is any laminated windshield or laminated window glass broken or splintered, which might cause injury when touched.</p> <p>There is any window to the side of the driver or behind the driver's location, which is not laminated or tempered safety glass.</p> <p>There is any crack in non-laminated safety glass.</p>
---	--	--

A. INSIDE		
20. Windshield, Side & Rear Windows (continued)		
Inspection Procedures:	Repair if:	Out of Service if:
b. Visibility/Fogging: 1) Check windshield and windows for fogging, reduced visibility, or improper level of tinting.	Glass fogging around edges, but less than two (2) inches.	The windshield or any window is fogged more than two (2) inches in from the outer border. Any windshield or window fogging or clouding results in reduced visibility of a mirror. There is any reduced visibility through the windshield or any windows.
2) Check windshield and windows for objects or signs obstructing driver's vision.		Any non OEM object obstructing or interfering with driver's vision to the front, sides, or rear. Any loose items located on dash or between dash and windshield. Any non-SCDE sign, or placard placed or mounted in or on any glass except the following approved locations. Left Side – First window behind driver's window, lower glass Right Side – Second window behind service door lower glass Rear – Right rear glass lower half
c. Latches and Window Operation 1) Check latches and windows for condition and operation.	Latches are broken. Latches are hard to operate, or any window does not move up and down freely. Windows do not stay closed.	There is any loose or damaged window hardware protruding into the passenger compartment.

A. INSIDE 20. Windshield, Side & Rear Windows (continued)		
Inspection Procedures:	Repair if:	Out of Service if:
d. Visor 1) Check driver's sun visor for correct type, condition, and operation.	The driver's sun visor is clouded, dirty or has unauthorized stickers. The driver's sun visor is incorrect type for year model being inspected.	The driver's sun visor cannot be adjusted or will not stay in position. The driver's sun visor is cracked, broken or damaged. Sun visor is missing.
e. Prism 1) Check prism on rear window. (If equipped)	Prism is missing, dirty, obstructed, not properly installed, or not Rear scope.	
A. INSIDE 21. Child Reminder Alarm, Electronic Communication Equipment (if equipped)		
1) a. Child Reminder (Walk Through) Alarm Check system for proper operation.	The system does not function as designed.	
a. Electronic Communication Equipment 1) Inspect tablet, radio, camera, GPS and antenna for mounting, location, and routing of wiring. 2) Mobile Eye Collision Avoidance System	Mounting is loose. Driver must move out of the normal driving position to operate radio (if on buses advise district). Wiring or connectors are improperly insulated, installed, routed, or secured so as to create the potential for a short. (If on buses disconnect power and advise district.) Mobile Eye system inoperative Mobile Eye not mounted in OEM location	Any forward view camera or dash cams that impedes drivers view of any mirror. Disconnect must be performed before the bus can operate.

A. INSIDE 22. Interior Wiring, Bulkhead/Firewall Seals		
Inspection Procedures:	Repair if:	Out of Service if:
a. Interior Wiring 1) Inspect visible wiring for mounting, condition, chafing/abrasion, corrosion, loose connectors, or improper repairs.	Wiring or connectors are unsecure, corroded, improperly routed, or interfere with driver's controls.	Any wire or connector is cut or severely chafed, or conductor is exposed or routed against a sharp edge. Any connection of any connector is not secure.
2) Inspect fuse/electrical panel and cover/door for mounting, condition and components.	The fuses/electrical panel and cover/door are not mounted securely or corroded but not in danger of shorting or failing.	Fuse/electrical panel and cover/door is not mounted securely or corroded and in danger of shorting or failing. The panel is not covered, or cover/door will not remain closed. Any components of the panel are missing.
b. Bulkhead Seals 1) Inspect bulkhead / firewall for any cracks, unsealed openings, and sound insulation material.	Sound deadening/insulation package is unsecured or deteriorated.	There is any open hole or unsealed area in the bulkhead / firewall.
A. INSIDE 23. General Condition, Interior		
a. Floor 1) Inspect floor covering, aisle, and cove molding strips for condition, adhesion and/or fastening holes or cracks, and ribbed rubber on aisle. 2) Inspect plywood underlayment for soft floor conditions.	Rubber floor covering is loose, deteriorated, or cracked. Cove molding is loose, or fasteners are missing.	There are unsealed holes or cracks through to the underside of bus. The aisle is not equipped with 12-inch-wide ribbed rubber. Any aisle molding strip is not securely fastened to floor, or any aisle or cove molding presents a sharp edge or protrusion or a tripping hazard. (Continued on Next Page)

		There is any damage to rubber floor covering which could cause a tripping hazard. Any soft floor conditions found.
--	--	---

A. INSIDE
23. General Condition, Interior (continued)

Inspection Procedures:	Repair if:	Out of Service if:
b. Paneling 1) Check all interior sidewall, rear, ceiling, and driver's area paneling for secure fastening, projections or sharp edges, and condition.	There is graffiti or unauthorized stickers on interior panels. (if on buses advise district) There are loose or missing attachment screws on any maintenance access panel. Interior paneling is severely mildewed, or paint (where required) is missing or damaged.	Interior paneling has any projections or sharp edges. Any Missing Panels.
c. Trash Can/Broom/Broom holder 1. Check to see that approved trash cans are present in all buses and are properly secured. 2. Check to see that brooms/broom holder (if present) are properly secured in approved locations.	Trash can is damaged or missing. Broom securement loose.	The trash can is not properly secured. The broom is not properly secured.
d. Engine Cover, if equipped 1) Inspect engine cover for seals, soundproofing, weather stripping, prop-rod and latch operation.	Soundproofing is not present or deteriorated.	Seals or weather stripping allow air/fume leaks into driver's compartment. Engine cover not secured properly.
e. Cleanliness: 1) Inspect the interior for cleanliness.	Bus is dirty. <u>Advise district.</u>	Bus is dirty and unsafe to operate. <u>Advise district.</u>

A. INSIDE 23. General Condition, Interior (continued)		
Inspection Procedures:	Repair if:	Out of Service if:
f. Loose Objects 1) Check to see that all objects on the bus are secured.		Any carpeting or non-O.E.M. floor mats. Any aerosol cans or other containers of flammable, hazardous, or volatile chemicals or liquids are on the bus. Loose objects are present and are not properly secured.
A. INSIDE 24. Wheelchair Lift, Door & Securement System		
Inspection Procedures:	Repair if:	Out of Service if:

<p>a. Wheelchair Lift, Door, and Securement System:</p> <p>1) Operate lift through complete cycle and inspect for proper operation, condition, safety features, manual backup system, fluid leaks, mounting, barrier operation, warning light, buzzer operation, and overall mechanical condition.</p>	<p>The dome light inside the lift area is inoperative.</p> <p>Lift door or latch does not operate smoothly.</p> <p>Lift light at exterior lift area (if equipped) is inoperative.</p> <p>Lift control cable or wiring is damaged or routed improperly.</p> <p>(Continued on Next Page)</p>	<p>Lift platform end barrier or handrail (if equipped) does not raise and lower reliably to the proper position. Barrier does not lock in position or is damaged.</p> <p>Fluid leakage.</p> <p>Lift does not fold, unfold, raise and lower properly, or jerks and binds.</p> <p>Lift is not mounted securely to the vehicle.</p> <p>There is excessive side play in the lift mechanism when the platform is partially or fully extended.</p> <p>Door switch (to prevent lift operation when the lift door is closed), or other safety override features do not function as designed.</p>
---	---	--

A. INSIDE		
24. Wheelchair Lift, Door & Securement System (continued)		
Inspection Procedures:	Repair if:	Out of Service if:
a. Wheelchair Lift, Door, and Securement System: (continued)		<p>The lift jacks the vehicle.</p> <p>Any part of the lift mechanism or hardware is damaged, missing, or not secure including cams, clips, pins, rollers, and platform fasteners.</p> <p>The manual backup system does not function properly.</p>
2) Buzzer: Operation according to specifications		Lift door warning buzzer or light does not operate according to specifications.
2) Inspect wheelchair and occupant securement (tie-down) system for condition, mounting, proper type, and location.	The track is filled with dirt.	<p>Wheelchair tie down track or fasteners are loose, broken, or damaged.</p> <p>Wheelchair or occupant securement straps are broken, frayed, or will not operate.</p> <p>Automatic retracting belts for wheelchair have been replaced with manual adjusting belts.</p> <p>Wheelchair or occupant securement track is mounted using lag bolts or sheet metal screws</p>

End of Section

SCDE
Vehicle Inspection Procedures
and
Repair/Out of Service Criteria

Section 7
Outside of Vehicle

B. OUTSIDE 1. Annual Inspection Certificate		
Inspection Procedures:	Repair if:	Out of Service if:
a. Annual Inspection Certificate 1) Check certificate validity, location, and condition.	Not located in approved location, Peeling, Slightly Faded	Expired, Missing, not legible, month not punched or Severely Faded
B. OUTSIDE 2. Headlights, Turn Signals, Hazard, Side Marker, Brake Tail, Backup Lights, Backup Alarm (if equipped), and Park Lights		
a. Headlights: 1) Check all headlights for brightness, operation, condition of sealed beams, type and visible misalignment. 2) Check Daytime Running Lights (if equipped) for proper operation. 3) Buses originally equipped with LED headlights should remain LED.	Left and right sealed beams are of different types (halogen and LED) Any lens beginning to fog or fade Headlights not HALOGEN or LED Trim rings not present. (if equipped) Upon visible inspection, there is any obvious misalignment of headlights due to adjustment. Headlights do not automatically turn on with windshield wipers. DRLs fail to function properly.	Either headlight does not light on low or high. Any lens is fogged or faded to the point that it diminishes headlight output. Any lens is cracked, or light is dim. Any LED is defective. Lights go out after being on a short time, or operation is intermittent. Upon visible inspection, there is any obvious misalignment of headlights due to loose, damaged, or missing adjustment or mounting hardware. Reflective material is peeling from sealed beam.
3) Check high beam indicator operation	High beam indicator doesn't light.	(Continued on Next Page)

		Any front, rear, or side-mounted turn signal lens is damaged, and white light is visible.
--	--	---

B. OUTSIDE
2. Headlights, Turn Signals, Hazard, Side Marker, Brake Tail, Backup Lights, Backup Alarm (if equipped), and Park Lights (continued)

Inspection Procedures:	Repair if:	Out of Service if:
<p>c. Hazard Lights: 1) Check four-way hazard lights and lenses for operation and condition.</p> <p style="text-align: center;">(Continued on Next Page)</p>	<p>Any lens is cracked or dirty.</p> <p>Either indicator fails to function properly.</p>	<p>Any four-way hazard light fails to function.</p> <p>Hazard lights do not flash between 60 and 120 times per minute.</p> <p>The switch does not function or will not maintain its set position when the steering wheel is turned.</p> <p>The switch is damaged, not securely mounted, or knob/button is missing.</p>

<p>d. Brake Lights: 1) Check brake lights and lens(es) for operation, condition, and specifications.</p>	<p>Fewer than half of the O.E.M. installed regular brake lights fail to function when the brake pedal is depressed. (i.e., 1 of 4)</p> <p>Any brake light lens is cracked, and white light is not visible.</p> <p>High mount brake light fails to function (if equipped)</p>	<p>Half or more of the O.E.M. installed regular brake lights fail to function when the brake pedal is depressed. (i.e., 2 of 4, 1 of 2 or more)</p> <p>After the brake pedal is released, brake light switch sticks, or lights stay on.</p> <p>Any brake light lens is damaged and white light is visible.</p> <p>Any brake light lens is not red or is not proper type meeting SAE specification or lens has darkened, faded, or is dirty, significantly affecting the visibility or color of the light.</p>
--	--	---

B. OUTSIDE		
2. Headlights, Turn Signals, Hazard, Side Marker, Brake Tail, Backup Lights, Backup Alarm (if equipped), and Park Lights (continued)		
Inspection Procedures:	Repair if:	Out of Service if:
e. Taillights: 1) Check taillight(s) and lens(es) for operation, condition, and specifications.	Fewer than half of the O.E.M. installed taillights fail to function when the headlight switch is in either the park or headlight positions. (i.e., 1 of 4) Any taillight lens is cracked, and white light is not visible.	Half or more of the O.E.M. installed taillights fail to function when the headlight switch is in either the park or headlight positions. (i.e. 2 of 4, 1 of 2 or more) Any taillight lens is damaged and white light is visible. Any taillight lens is not red or is not proper type meeting SAE specifications. Any taillight lens has darkened, faded, or is dirty, significantly affecting the visibility or color of the light.
f. Backup Lights: 1) Check backup lights and lens(es) for proper operation and condition.	One of the installed backup lights fails to function. Any backup lens is cracked.	More than one installed backup lights fail to function. Backup light(s) stays on all the time or stays on in any gear position other than reverse.
g. Backup Alarm: 1) Check for presence of back up alarm. Check operation of alarm by placing transmission in reverse (automatic transmission – engine running) and listening for alarm sound.	Alarm mounting loose.	Backup alarm does not sound.

B. OUTSIDE		
2. Headlights, Turn Signals, Hazard, Side Marker, Brake Tail, Backup Lights, Backup Alarm (if equipped), and Park Lights (continued)		
Inspection Procedures:	Repair if:	Out of Service if:
h. Park Lights: 1) Check Park lights and lens(es) for proper operation and condition.	Park light(s) fail to function. Any park light lens is cracked or damaged.	
i. Clearance, Marker, and ID lights: 1) Check light(s) and lens(es) for operation, condition, and location.	When viewed from front, rear, or side: At least 1 light is working when viewed from that direction. Any clearance or ID lens is not amber if in front of the rear wheels or red if at or behind the rear wheels. Any clearance light lens has darkened, faded, or is dirty, significantly affecting the visibility or color of the light. Any clearance light switch is hard to operate, sticks, or knob is missing. Any clearance or ID light lens is damaged and white light is not visible.	When viewed from front, rear, or side: None of the lights are working when viewed from that direction. Any clearance or ID light lens is damaged and white light is visible.
j. License plate/light(s): 1) Check license plate and light(s) and lens(es) for condition and operation.	License plate light not over tag is inoperative. The license plate is faded.	License plate light over tag is inoperative License plate (or dealer tag) is loose or missing. License (or dealer tag) is illegible.

B. OUTSIDE 2. Headlights, Turn Signals, Hazard, Side Marker, Brake Tail, Backup Lights, Backup Alarm (if equipped), and Park Lights (continued)		
Inspection Procedures:	Repair if:	Out of Service if:
k: Strobe Light: (bus) 1) Check roof mounted white flashing strobe light for operation, location, condition, and protective guard if equipped (all buses manufactured 1995 and later).	Protective guard is missing if required Strobe light is missing or does not function.	Protective guard is loose
l. Reflectors: 1) Check reflectors for condition and location.	Any OEM installed reflector on either side of the bus is missing, damaged, cracked, or faded. Any OEM installed reflector on either the front or the rear of the bus is missing, damaged, cracked, or faded.	
m. Rooftop light bar: 1) Service trucks and wreckers.	Service Trucks/Wrecker: Switch not properly mounted in dash.	Wreckers: Light bar is missing, inoperative, lens cracked or broken, lens/light any color other than amber. Service Trucks: Light bar is missing, inoperative, lens cracked or broken. Brake lights (RED) Wreckers: Tow lights are missing or not properly secured

B. OUTSIDE		
3. Eight Light Warning System		
Inspection Procedures:	Repair if:	Out of Service if:
<p>a. Pupil Warning Lights</p> <p>1) Check pupil warning lights for operation and condition.</p> <p>2) Rear motorist alert if equipped</p>	<p>Either pupil warning light pilot light fails to function.</p> <p>Any pupil warning light hood is damaged but does not obstruct the visibility of the light.</p> <p>Any pupil warning light hood is missing. (If OEM equipped)</p> <p>Flash patterns do not match</p>	<p>Any amber or red light does not function or is dim.</p> <p>Any amber or red LED light fails to operate or is dim</p> <p>Amber/red lights (both front and rear) do not alternately flash (side to side).</p> <p>Amber/red lights are mixed flashing or strobe.</p> <p>Any pupil warning light is not red (outer) or amber (inner) or is not proper type.</p> <p>Any pupil warning light lens is damaged, and white light is visible or is not proper type.</p> <p>Any pupil warning light lens has darkened, faded, is misaligned, or is dirty, affecting the color of the light or reducing the visibility to less than 500 feet in bright sunlight.</p> <p>Pupil warning lights do not function according to all conditions in the Chart.</p> <p>Any pupil warning light hood is damaged so that it obstructs visibility of the light.</p> <p>Rear motorist alert does not function</p>

B. OUTSIDE		
4. Stop Arm, Crossing Arm, Child Safety Alarm		
Inspection Procedures:	Repair if:	Out of Service if:
<p>a. Stop Arm</p> <p>1) Check stop arm for specifications, operation (see Chart), and condition.</p> <p>Note: All criteria pertain to both systems for buses equipped with front and rear stop arms.</p>	<p>Wiring-ground strap is broken, loose, or not properly routed and secured. (88 only)</p> <p>Any lens is cracked, and no white light is visible.</p> <p>Hinge or bushing(s) is worn or needs lubrication.</p> <p>Stop arm assembly or blade mounting is loose.</p> <p>Retraction is slow.</p> <p>Any stop arm (paint or decal) is significantly faded or discolored.</p> <p>Any water is visible inside the lens.</p>	<p>Wiring: insulation missing exposing copper or wire(s) is broken.</p> <p>Any lens is cracked, damaged, broken, or missing and white light is visible.</p> <p>Any stop arm light or illumination does not function</p> <p>Lights do not flash alternately.</p> <p>Stop arm does not extend to approximately 90 degrees or retract.</p> <p>Any stop arm has an air leak.</p> <p>The stop arm does not operate according to all the conditions in Chart.</p> <p>Stop arm not of proper type and specifications:</p> <ol style="list-style-type: none"> 1) Octagonal, red w/ white border (all). 2) Flashing red lights (all). 3) High intensity reflectivity

B. OUTSIDE		
4. Stop Arm, Crossing Arm, Child Safety Alarm (continued)		
Inspection Procedures:	Repair if:	Out of Service if:
b. Student Crossing Arm (all buses): 1) Check front bumper mounted student crossing arm for operation, condition, and mounting.	Hinge or bushing(s) is worn or needs lubrication. Arm assembly or blade mounting is loose. Loop-rod/arm is distorted, or U-bolts are loose. Blade is not an approved type.	Arm does not extend to approximately 90 degrees and retract. Any arm has an air leak. Arm does not operate according to all the conditions in Chart. Loop-rod/arm is missing, broken, or is not a minimum of 67 inches in length.
c. Child Safety Alarm (If equipped): 1) Check operation of child safety alarm.	Does not activate automatically when the stop arm/crossing gate begins retracting. Does not de-activate automatically after a brief time period. Does not operate as described in chart.	

B. OUTSIDE		
5. Batteries:		
Inspection Procedures:	Repair if:	Out of Service if:
a. Batteries (12 volt): 1) Check for condition and type. 2) Electric buses must have AGM batteries 4) Battery cutoff switch/HV reset switch	Battery top or sides are corroded, greasy, dirty.	Cracked, damaged or leaking. Battery will not start vehicle. Batteries are not correct type
b. Hold-down: 1) Check for tightness, condition, and type of battery hold-down.	Hold-down assembly or tray is corroded or damaged, but battery is secure.	Hold-down assembly or tray is loose, corroded, or damaged causing insecure mounting of battery. Any non-OEM strap or hold-down. Hold-down/Batteries are mounted in such a way that they could short out against the hold-down and/or anybody or chassis component.
c. Battery Terminals: 1) Check terminals for type, cleanliness, tightness, and condition.	Terminals are dirty, corroded or loose and/or have missing parts.	Batteries have the wrong style terminals for the vehicle or are installed with adapters.

B. OUTSIDE 5. Batteries: (continued)		
Inspection Procedures:	Repair if:	Out of Service if:
<p>d. Battery Cables:</p> <p>1) Check cable assemblies for routing, securement, condition, and size.</p>	<p>Cable is corroded.</p> <p>Negative cable or insulation is cracked or damaged.</p> <p>Negative cable is misrouted, or grommet is missing to allow it to abrade on any metal or sharp edge.</p> <p>Cable appears to be of excessive length.</p> <p>The flat braided engine ground cable is frayed, corroded.</p>	<p>Positive cable insulation is cracked or damaged.</p> <p>Positive cable is misrouted, unsecured, loose, or grommet is missing to allow it to abrade on any metal or sharp edge.</p> <p>Cable is routed against the exhaust or any other extremely hot surface.</p> <p>PVC is not installed. (Metal battery box) (exception: 2018 Bluebird Type D and Propane)</p> <p>Cable is smaller than original equipment size.</p> <p>Any ground cable ends are not secure.</p>
<p>e. Tray:</p> <p>1) Check battery tray for operation, condition, and securement.</p>	<p>Battery slide tray is corroded or dirty, or hard to slide in and out.</p>	<p>Battery slide tray securement device or tray stop is missing or nonfunctional.</p> <p>Battery tray does not slide in and out.</p> <p>Battery slide tray or box is damaged or deteriorated reducing security of battery(ies).</p> <p>Battery box door does not open or will not stay latched.</p>

B. OUTSIDE 6. Electrical Compartment and/or AC Compartment		
Inspection Procedures:	Repair if:	Out of Service if:
a. Door: 1) Inspect door for condition, operation, mounting, and seal. (if equipped)	Hinge, door, latch, and/or seal are loose or damaged but still functional. Lettering (outside) or wiring diagram (inside) missing	Hinge, door, and/or latch are damaged and do not function or are missing. The door seal is damaged or missing.
b. Compartment: 1) Inspect panel(s) and components for mounting, routing and placement. Inspect visible wiring for mounting, condition, chafing/abrasion, corrosion, loose connectors, or improper repairs. 2) Fuel fill/EV charge port	Wiring or connectors are unsecure, corroded, or improperly routed. Any panel or component is not properly mounted or loose but not in danger of shorting or failing. Any water intrusion. Any damage to outer door	Any wire or connector/connection is cut or severely chafed, or conductor is exposed or routed against a sharp edge and is in danger of shorting or failing. Any panel or component is not properly mounted or loose and is in danger of shorting or failing. Any component or circuit that is not protected by a fuse, circuit breaker or fusible link. Fuel cap missing or damaged fill neck/LPG port. Any damage to EV charge port components
3) Inspect compartment light(s) for condition and operation.	Light does not function, or lens is missing or damaged. (if equipped)	There is damage or condition that could result in a short.
B. OUTSIDE 7. General Condition, Exterior		
a. Mirrors: 1) Check all exterior mirrors, mounting and brackets for tightness and condition.	Mirror brackets are bent or broken, or mounting is unsecure, and mirror will remain properly adjusted.	Mirror brackets are bent or broken, or mounting is unsecure, and mirror will not stay in the adjusted position or cannot be adjusted. Cross view mirrors do not extend beyond the leading edge of the vehicle. Brackets are non-OEM or mis-matched.

B. OUTSIDE 7. General Condition, Exterior (continued)		
Inspection Procedures:	Repair if:	Out of Service if:
b. Bumpers: 1) Check bumpers for mounting, condition, color, body seal and end caps (rear bumper).	Bumper end caps are missing. Bumper is equipped with any unauthorized stickers or decals. The bumper is not adjusted properly. (i.e., interferes with hood opening)	Bumper is bent away from body or has protruding metal. Bumper mounting system has cracked, broken, or bent brackets, braces, welds, or missing or loose fasteners. Bumper is cracked, torn, or broken. Bumper is not OEM, approved type or COLOR.(example: EV must be blue).
c. Body Damage 1) Check body exterior for accident damage, scratches, dents, etc.	The body has small dents, scratches, etc. The body has small rust spots or water leaks. Mud flaps loose, torn, or missing.	Any body part is damaged or dislocated creating a protrusion or sharp edge. Body panels, rivets, or other components are loose, damaged or corroded to the point where joint strength or body structural integrity is compromised. Body panels/parts missing.
d. Paint: 1) Check paint on body and trim for required coloration and condition.	Paint is severely faded, discolored, rusted, or damaged.	

B. OUTSIDE		
7. General Condition, Exterior (continued)		
Inspection Procedures:	Repair if:	Out of Service if:
<p>e. Reflective Markings (if equipped):</p> <p>1) Check reflective markings for coloration, reflectiveness and condition. Check for presence of reflective markings around any emergency exit (door, window, or roof hatch) along both sides at floor line and around rear perimeter of bus.</p>	<p>Reflective markings are faded, discolored, damaged or peeling.</p> <p>Side reflective markings are faded, discolored, damaged or peeling</p>	<p>Any required reflective markings are missing.</p> <p>Any emergency exit, roof hatch, or rear perimeter reflective markings are missing, faded, or discolored</p>
<p>f. Lettering:</p> <p>1) Buses - Check all lettering for required type, size, location, and color.</p> <p>Note: "SCHOOL BUS" lettering front and rear must be on reflective backing.</p> <p>(Continued on Next Page)</p>	<p>Fuel type lettering is not present.</p> <p>Any handicapped symbol (if required) is not reflective white on blue background, minimum six inches by six inches (6" x 6").</p> <p>SCDE bus number is not present or readable.</p>	<p>Any required lettering is not readable.</p> <p>The bus is not equipped with the following lettering:</p> <ol style="list-style-type: none"> 1) Eight inch (8") "SCHOOL BUS" front and rear. 2) Six-inch (6") minimum "SOUTH CAROLINA PUBLIC SCHOOLS" left and right sides of body 3) Handicapped symbol (3) installed on front, rear and lift door (ALL wheelchair lift equipped buses). 4) Minimum two-inch (2") lettering "Emergency Door" at top or above door. 5) Emergency door(s) and emergency window(s) or hatch(es) not labeled "Emergency Exit" or "Emergency Door" on outside. 6) Any required lettering (except handicapped symbol) is not black. (Except

		those equipped with white lettering with black background)
--	--	--

B. OUTSIDE
7. General Condition, Exterior (continued)

Inspection Procedures:	Repair if:	Out of Service if:
<p>f. Lettering: (continued)</p> <p>1) Tankers</p>	<p>Fuel placard slightly faded but color is still red.</p> <p>SCDE logo seal faded or peeling</p>	<p>Fuel placard extremely faded (pink), not legible, missing, or wrong fuel type.</p> <p>SCDE logo seal not on front doors.</p>
<p>g. Emergency Door Operation</p> <p>1) Check emergency door for operation from exterior of bus.</p> <p>Note: Emergency door(s) must be equipped with a self-canceling device to hold the door open during use.</p>	<p>Emergency doors equipped with a link or strap that prevents the door from opening too far and causing damage. This should be working, not damaged, tight, and should not interfere with the operation of the door.</p> <p>Side emergency door seal damaged or does not effectively prevent water, and/or dirt from entering bus.</p>	<p>Emergency door(s) is hard to open fully (at least 90 degrees) from outside of bus.</p> <p>Emergency door(s) latch mechanism requires more than 40 pounds of force to release.</p> <p>Hold open device (if equipped) is non-operational, bent, damaged or loose.</p> <p>Emergency door(s) exterior handle is not OEM style and mounting.</p> <p>(Continued on Next Page)</p>

		Rear emergency door seal damaged or does not effectively prevent exhaust, water, and/or dirt from entering bus.
--	--	---

B. OUTSIDE
7. General Condition, Exterior (continued)

Inspection Procedures:	Repair if:	Out of Service if:
<p>h. Engine Hood</p> <p>1) Check engine hood for operation, condition, and safety latch.</p> <p>Check operation of starter interlock switch if applicable (rear engine).</p>	<p>Hood is misaligned or out of adjustment.</p> <p>Fiberglass hoods, fender extensions and/or cowls show signs of unusual wear or damage.</p> <p>Any hood socket, rubber cone or wedge is missing, loose, or damaged.</p> <p>Any rubber/plastic hood bumper or gasket is missing, loose, or damaged.</p> <p>Any hinge is missing, loose, or damaged.</p> <p>Hood latch is loose or damaged.</p>	<p>Hood cannot be opened as designed.</p> <p>Hood latch does not secure the hood.</p> <p>Hood support cables are loose, broken, or missing (tilt hood).</p> <p>The interlock switch does not function as designed or has been bypassed.</p> <p>Any hood hold-open feature (rod, strut, self-locking support, etc...) is missing, loose, or damaged.</p>
<p>I. Windshield Folding Steps and Grab Handles:</p> <p>1) Check the condition and mounting of windshield folding steps and grab handles.</p>	<p>Any windshield step or grab handle is missing.</p>	<p>Any windshield step or grab handle is loose or broken.</p>

j. Cleanliness 1) Check the exterior of the bus for cleanliness.	The exterior is dirty. <u>Advise district.</u>	Vehicle is dirty to the point visibility through any window or light lens is significantly reduced. <u>Advise district.</u>
--	---	--

B. OUTSIDE
7. General Condition, Exterior (continued)

Inspection Procedures:	Repair if:	Out of Service if:
k. Safety equipment, Trucks: 1) Fire Extinguisher: a) Check for presence of fire extinguisher and for the following:		No fire extinguisher present.
b) Check Manufacturer's Label		Labeling is not legible to determine size and type
c) Rating: check for proper U.L. (Underwriters Laboratory) rating.		Service Trucks 5 lb. 10BC) Tankers - 1 (one) 10 lb. 2A-10BC or 2 (two) 5.0 lb. 2A-10BC
d) Pressure: check gauge		Pressure above or below green zone.
e) Mounting: check for accessibility and secure mounting.	The bracket mount to panel is loose.	Fire extinguisher not accessible to driver or not secured in mounting bracket.
f) Nozzle (If applicable) check for loose or damaged parts.		Nozzle loose, missing, obstructed or excessive damage to any parts of extinguisher.
g) Safety Pin: check for presence of safety pin and tamper proof seal.	Seal is broken	The safety pin is missing. Tamper proof seal not of approved type. (i.e., material cannot be broken easily)
2) Spill clean-up/containment kit. Check for presence and that the kit is complete.	Kit not securely mounted or stored in a side compartment.	No kit on vehicle. Parts of the kit have been used and not replaced.

B. OUTSIDE 7. General Condition (Exterior) (continued)		
Inspection Procedures	Repair If:	Out of Service If:
I. Exterior OEM Cameras (backup, 360 view): 1) Mounting, operation, and general condition Note: 360 view cameras are located on the hood, on either side of the roof, and on the rear of the bus.	Camera not mounted, secure, or is missing. Camera body or lens damaged. Damage projects picture distortion or no picture.	

End of Section

SCDE
Vehicle Inspection Procedures
and
Repair/Out of Service Criteria

Section 8
Engine Compartment
of Vehicle

NOTE: This Manual is laid out to logically coincide with the inspection of front engine vehicles. Rear engine vehicles may have to be inspected in a different sequence, but all the componentry and procedures still apply.

C. ENGINE COMPARTMENT		
1. Fluid Levels and Conditions		
Inspection Procedures:	Repair if:	Out of Service if:
a. Brake Fluid: 1) Check brake fluid and brake power-assist hydraulic fluid (if equipped) for level and condition.		Level of brake fluid in either side of master cylinder reservoir is low or below "Add" mark (if equipped). Brake fluid or power-assist fluid shows evidence of contamination. Brake power-assist hydraulic fluid is below cold "Add" mark.
b. Power Steering Fluid: 1) Check power steering fluid level and condition.		Power steering fluid is below cold "Add" mark. Power steering fluid shows evidence of contamination.
c. Oil: 1) Check the level and condition of the oil.	(Continued on Next Page)	No oil is observed on dipstick. There is evidence of fuel or water contamination in the oil or an overfill condition. Dipstick is missing. Oil level is at or below add mark.

C. ENGINE COMPARTMENT		
1. Fluid Levels and Conditions (continued)		
Inspection Procedures:	Repair if:	Out of Service if:
d. Transmission Fluid: 1) Check the level and condition of transmission fluid. (Observe proper procedure when checking level)	Transmission fluid shows need of servicing (discoloration and/or burnt smell).	Transmission fluid shows evidence of excessive contamination or an overfill condition. Transmission fluid is not present on dipstick. Transmission fluid is at or below "Add" mark.
e. Windshield Washer Fluid: 1) Check windshield washer fluid level.	Reservoir is low or the washer does not spray the windshield.	
f. Coolant: 1) Check coolant (antifreeze) level and condition.	Coolant level in radiator or reservoir is low but still visible in tank. Coolant shows evidence of rust and corrosion contamination.	Coolant level in radiator or reservoir is low and not visible in tank. Coolant shows evidence of excessive oil or fuel contamination.
C. ENGINE COMPARTMENT		
2. Belts and All Hoses		
a. Belt(s): 1) Tension. Visually and physically check all drive belts for proper tension. Note: If available, use a tension gauge. If a gauge is not available, use a ruler to measure the deflection of the belt(s) up and down at the widest point between the drive and driven pulley(s). (See illustrations on page 8-7.)	Any belt exceeds tension reading recommended by manufacturer if a tension gauge is used. Using ruler method, any belt is less than ½ inch deflection (too tight) when firm pressure is applied.	Any belt tensioner does not pivot or move freely and apply spring pressure on belt. Tension on any belt is too loose (based on specifications of type tension gauge used). Tension of any belt (using ruler method) is too loose when firm pressure is applied (greater than 3/4-inch deflection).
(Continued on Next Page)		

C. ENGINE COMPARTMENT		
2. Belts and All Hoses		
Inspection Procedures:	Repair if:	Out of Service if:
a. Belt(s): continued 2) Condition: Visually inspect belt(s) for glazing, oil contamination, dry rotting, cuts, and separation of plies. Check belts for twisting or distortion.	Any belt is glazed.	Any belt is oil saturated, dry-rotted, or cut or plies of belt(s) are separated. Any belt is twisted or distorted.
3) Routing: Visually inspect belt(s) for rubbing or contact with objects other than pulleys and for routing around correct pulleys.		Any belt is contacting objects other than pulley(s). Any belt is routed around incorrect pulley(s).
4) Belt Alignment: Visually inspect belts for proper alignment.	Any belt is not inline. (Less than 1/16 inch per foot)	Belt misalignment is excessive and could result in failure. (More than 1/16 inch per foot)
(Continued on Fourth Page)		

Belt Inspection

1. Inspect all used drive belts (including those that are being replaced) for the following conditions:
2. Inspect for glazing (shiny sidewalls). Glazing is caused by friction created when a loose belt slips in the pulleys. It can also be caused by oil or grease on the pulleys.
3. Inspect for separating layers. Oil, grease, or belt dressings can cause the belt to fall apart in layers. If engine parts are leaking, repair the oil leaks. Do not use belt dressings on any belt.
4. Check for jagged or streaked sidewalls. These are the result of a foreign object (such as sand or small gravel) in the pulley, or a rough pulley wall surface.
5. Check for tensile breaks (breaks in the cord body). Cut belts are usually caused by large foreign objects in the pulley or by prying or forcing the belt during installation or removal.
6. On polyV belts check for uneven ribs. Foreign objects in the pulley will erode the under-cord ribs, causing the belt to lose its gripping power.
7. Inspect for cracks. Small, irregular cracks are usually signs of an old belt. Replace the belt if any of the above conditions are found. Replace both belts of a set, at the same time. Matched belts must be from the same manufacturer.

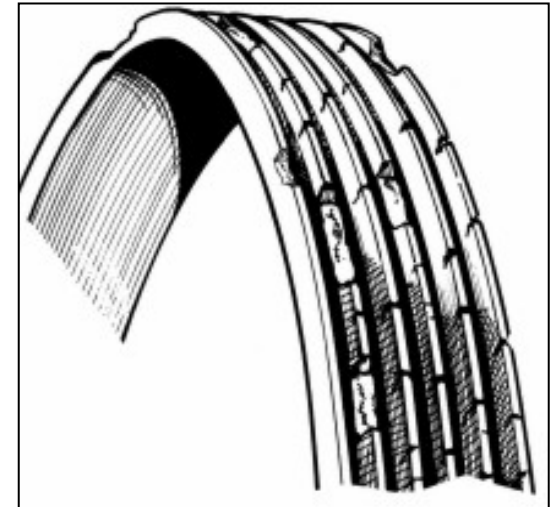
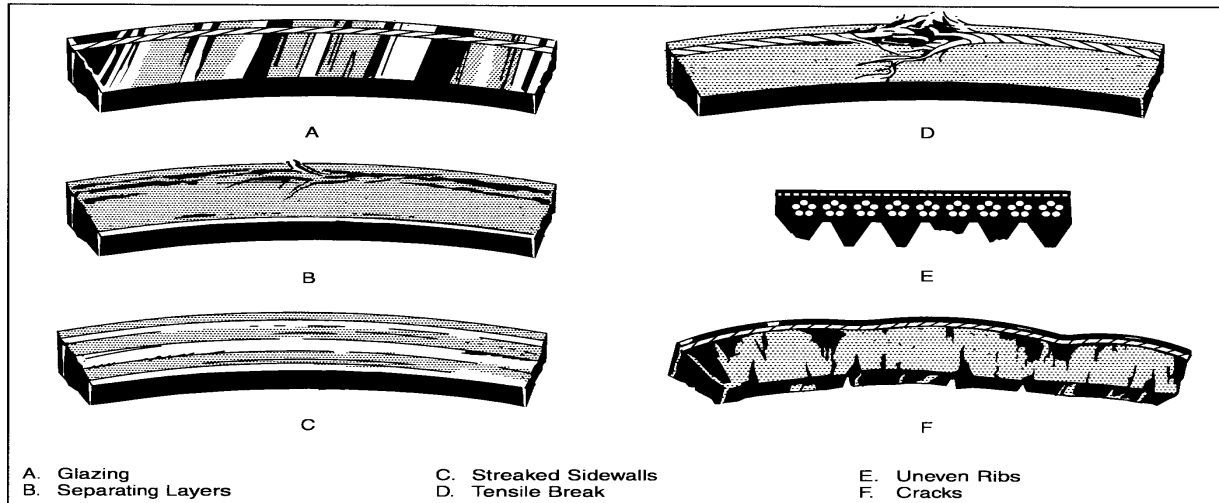

NOTE: For an installed belt, gently twist the belt about 90 degrees so you can see all surfaces.

Pulley Inspection

1. Check all pulley bearings for roughness. Replace the bearings if they are rough.
2. Inspect all pulleys for foreign objects, oil, or grease in the grooves. Use a nonflammable cleaning solvent to remove oils. Use a wire brush to remove rust, and a file to remove burrs.
3. Inspect the pulleys for wear on the inner walls. Hold a small straightedge against the inside of the pulley walls or use your little finger or fingernail to find grooves in the inner walls. If there are any grooves, replace the pulley.
4. Check alignment of pulleys. Use a thin straightedge that is longer than the longest span between the pulleys. Place the straightedge into the V-grooves of two pulleys at a time. The straightedge should be parallel to the outer edges of the pulleys; if not, the pulleys are misaligned.

Pulley misalignment must not be more than 1/16inch for each foot (1.5 mm for each 30.5 cm) of distance between pulley centers.

If there is misalignment of the pulleys, adjust the pulleys or brackets if their positions are adjustable. Replace bent or broken pulleys, pulley brackets, or shafts.

5. Check all drive component mounting parts for loose fasteners, cracks, or other damage. Tighten loose fasteners. Repair or replace cracked or damaged brackets.

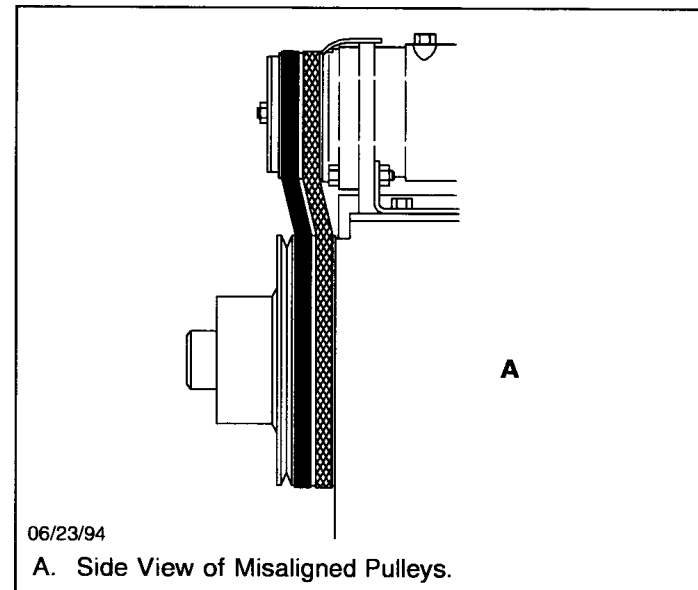
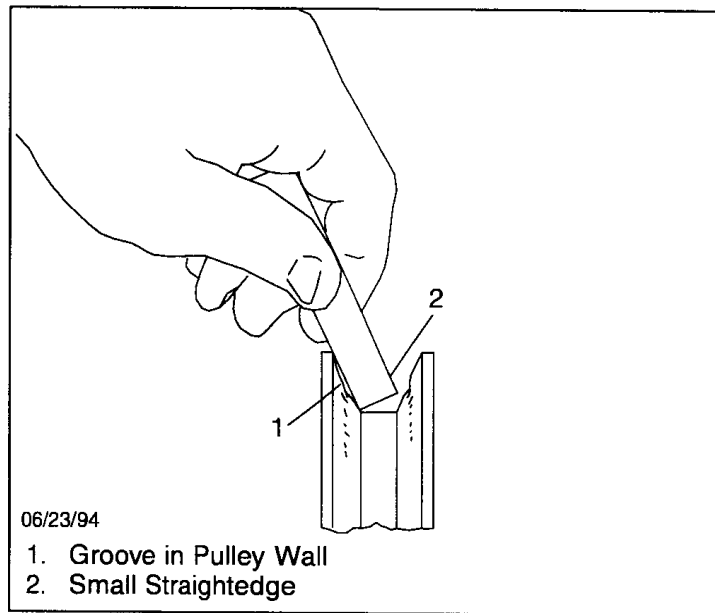

CHECKING BELT TENSION

FIGURE 9 - Checking Belt Tension
Gauge Method

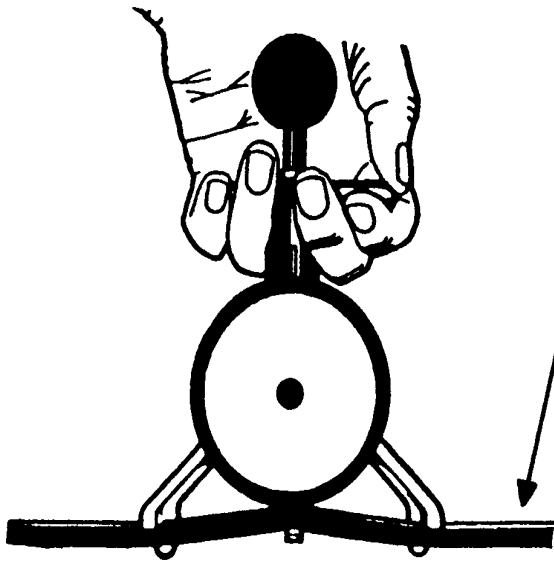
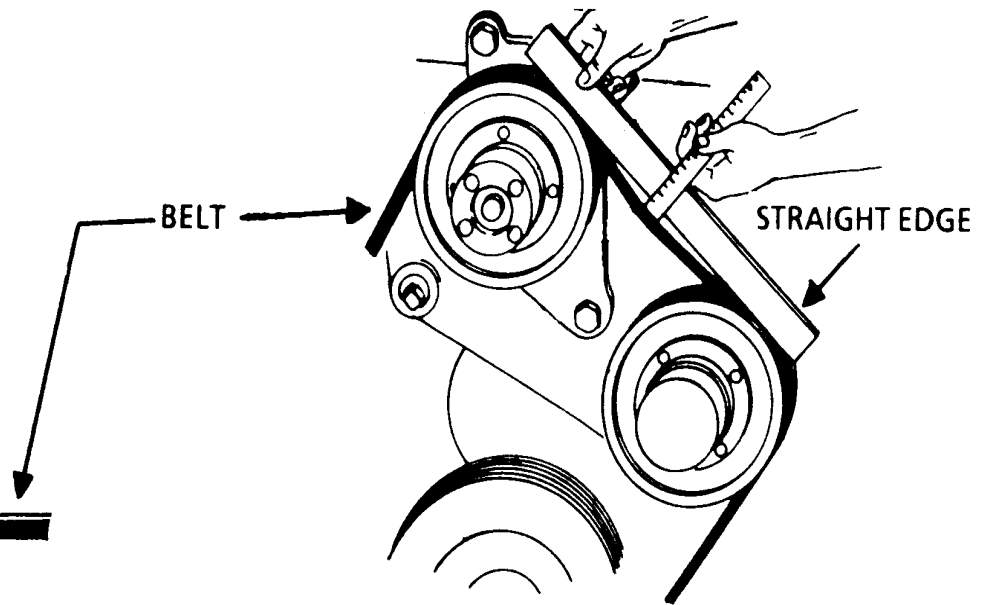

FIGURE 10 - Measuring Belt Tension
Rule Method



C. ENGINE COMPARTMENT		
2. Belts and All Hoses (continued)		
Inspection Procedures:	Repair if:	Out of Service if:
<p>b. Hose(s)</p> <p>NOTE: References to hoses include all types of hoses located in the engine compartment, including power steering, coolant, air compressor intake, vacuum, brake hydraulic assist, engine oil, and transmission hoses.</p> <p>1) Clamp(s) and Connections: Visually and physically check that hose connections or clamp(s) are tight.</p>	<p>Any hose connection or clamp(s) is loose or is too tight digging into hose.</p> <p>Any silicone hose does not have a constant torque type clamp on it.</p>	<p>Any hose connection or clamp(s) is stripped or damaged.</p>
<p>2) Condition: Visually inspect all hoses for cuts, abrasions and wear, oil saturation, dry rotting, or “ballooning.”</p>	<p>Any silicone hose has been exposed to diesel fuel by contaminated coolant.</p>	<p>Any hose is cut, abraded, worn, oil saturated, dry-rotted, or “ballooned” to the point that failure is imminent.</p>
<p>3) Routing: Visually inspect routing and securement of all hoses.</p>	<p>Any hose is misrouted or unsecured so that heat damage, abrasion, or cuts could cause long-term failure.</p>	<p>Any hose is misrouted or unsecured so that heat damage, abrasion, or cuts could cause imminent failure.</p>
<p>4) Type: Confirm hose is of the proper type for the application.</p>		<p>Any hose is found to be of the improper type for the application.</p>

C. ENGINE COMPARTMENT		
3. Engine Performance		
Inspection Procedures:	Repair if:	Out of Service if:
a. Engine Performance & Governor:		
1) Check for starting, proper idle, stalling.	Rough or low idle.	Engine will not start or is difficult to start. Engine stalls.
2) Check for missing or hesitation, performance when accelerating and excessive smoke.	Engine is smoking.	Engine is misfiring, skipping, or there is excessive hesitation upon acceleration.
3) Check the engine for any unusual noises, knocks, or rattles.	Noise source determined not to be harmful to engine.	Source of noise could result in engine failure.
C. ENGINE COMPARTMENT		
4. Components		
a. Air Cleaner:		
1) Check air cleaner assembly, housing, lid, piping, gasket(s), seal, clamp(s) for securement and condition.		Air filter restriction exceeds manufacturer's specifications.
Note: Do not disturb large two-stage air filters to check the condition of the element. If loosened or removed, it must be replaced.		Any portion of air cleaner assembly or mounting is loose or damaged, including piping, nuts, bolts or clamps.
		There are any worn or damaged seals or gaskets.
		There are any air or vacuum leaks or missing components.
	(Continued on Next Page)	

C. ENGINE COMPARTMENT		
4. Components (continued)		
Inspection Procedures:	Repair if:	Out of Service if:
a. Air Cleaner: 2) Air Restriction Gauge (diesel engines), check for presence and condition.		Any gauge found missing, damaged, or inoperative.
b. Turbo: 1) Inspect turbo and plumbing for leaks, mounting, connections, and condition.	Evidence of oil seepage.	Any leak is observed of air, coolant, exhaust, or oil. The heat shield is damaged or missing. Any mounting or connection is loose. Any unusual noise or vibration is observed.
c. Power Steering Pump 1) Check securement and condition of the power steering pump.	Pump has wrong type cap on reservoir.	Any portion of the power steering pump, mounting bracketry or fastener is cracked, loose, or missing. Cap missing

C. ENGINE COMPARTMENT		
4. Components (continued)		
Inspection Procedures:	Repair if:	Out of Service if:
<p>d. Air Compressor and Filter</p> <p>1) Check securement and condition of air compressor and filter assembly.</p> <p>Note: On EV buses check air compressor oil level. (mounted underneath bus)</p>	<p>Air compressor air filter (if equipped) is dirty.</p>	<p>Any loose, leaking or damaged hose or plumbing between engine air filtration system and compressor (on vehicles that share filter).</p> <p>Any portion of the air compressor, compressor air filter (if equipped), filter and compressor mounting bracketry, filter cover, or fastener is cracked, loose, or missing.</p> <p>Any oil or coolant leaks from compressor or plumbing.</p> <p>Any problem with piggy-backed power steering pumps, either mounting or leaks.</p>
<p>e. Water Pump</p> <p>1) Check the condition of the water pump and pulley.</p>	<p>Water pump fasteners are loose, damaged, or missing.</p>	<p>The water pump is noisy, or the bearing is damaged.</p> <p>There is coolant leaking from water pump, seal, gasket surface, or weep hole.</p>
<p>f. Fan</p> <p>1) Check fan blade and fan clutch/drive assembly for securement and condition.</p> <p>2) Check Rotary Union for excessive play and routing of airline.</p>	<p>Hydraulic/Pneumatic drive type fan always remains in the "on" position.</p> <p>Airline is routed incorrectly</p> <p>(Continued on Next Page)</p>	<p>Fan is not OEM type.</p> <p>Fan has any cracked, bent, or broken blades.</p> <p>Any portion of fan mounting is loose.</p> <p>Fan clutch is seized or loose.</p> <p>Rotary union has play.</p>

C. ENGINE COMPARTMENT 4. Components (continued)		
Inspection Procedures:	Repair if:	Out of Service if:
g. Fan (continued)		Any leak, mounting, rotation or function problem with hydraulic or Pneumatic components. Electric/Pneumatic fan does not operate. Hydraulic solenoid valve inoperative. Wiring for fan (electric) or solenoid (hydraulic) is not secured, loose, damaged, or missing.
h. Alternator 1) Check securement and condition of alternator assembly.	The alternator is noisy. Vehicle - Battery wire does not have a rubber insulating boot over the connection on the back of the Alternator.	Any portion of the alternator, mounting bracketry, or fastener is cracked, loose, or missing. Alternator is not charging. Pulley or fan is loose, bent or does not run true. Bearings are worn or damaged.
i. Starter 1) Check starter for securement and condition.		Wire/harness not firmly attached or routed improperly. Must be clear of exhaust. The starter will not start the vehicle. Starter drags, noisy or does not engage/disengage properly. Teeth missing from starter or flywheel.

C. ENGINE COMPARTMENT 5. Wiring		
Inspection Procedures:	Repair if:	Out of Service if:
a. Routing and Condition 1) Check routing, securement, and condition of all wiring and any electrical cable in the engine compartment. Note: Wiring must be in OEM condition. Wire must be replaced with proper size, type, and color. Routing should be OEM, properly secured, and in harness or loom where applicable. All OEM heat shielding must be intact.	There is any loose, damaged, or corroded wiring connector or terminal end. The replaced wire has not been removed.	There is any unsecured, poorly routed or damaged wiring or deteriorated loom/covering that could cause a potential short or fire due to abrasion or heat damage. Repairs have been made using improper wire gauge or method. EV high voltage loom is not ORANGE Missing heat shielding
C. ENGINE COMPARTMENT 6. Fuel System and Lines		
a. Fuel System and Lines 1) Visually check the condition, operation, and securement of all fuel system components, including pumps, fuel lines and routing.	There is evidence of contamination of the fuel water separator (if equipped).	There is any unsecured, or poorly routed, or loose fuel line or hose that could cause potential fire due to abrasion or heat damage. Any fuel system connection or component that is stripped, loose, cracked, or leaking. Any fuel system component is damaged or not mounted securely. Any evidence of fuel leaking internally and contaminating oil or coolant (pump, tubes, etc.). Any electric or mechanical shutdown that does not operate properly.

C. ENGINE COMPARTMENT		
7. Radiator/Cooling		
Inspection Procedures:	Repair if:	Out of Service if:
a. Radiator Mounting 1) Check radiator assembly and mounting for securement and condition.	Any portion of the radiator mounting system is cracked, damaged, or has loose or missing fasteners.	Any portion of the radiator is cracked or leaking.
b. Radiator Cap 1) Check the condition of radiator cap. WARNING: ALWAYS USE PROPER PROCEDURES WHEN REMOVING RADIATOR CAP.	Radiator cap is hard to open or close. The radiator cap has the wrong pressure rating. There is any visible damage to the pressure seat or vacuum relief seat of the cap.	The radiator cap is missing.
c. Reservoir (pressurized) 1) Check coolant reservoir (including de-aeration tank) and sight glass (if equipped) for mounting and condition.	Sight glass (if OEM equipped) has been replaced with plug.	Any portion of coolant reservoir or mounting system is missing, cracked or damaged, is leaking, or has loose or missing fasteners.
d. Coolant Recovery Tank (non-pressurized) 1) Check condition, securement, and operation.	Any problem with tank, connections, or missing parts.	
e. Fan Shroud 1) Check fan shroud for mounting and condition.	(Continued on Next Page)	Any portion of fan shroud or shroud mounting is cracked, damaged, or has loose, or missing fasteners. Fan shroud is missing.

C. ENGINE COMPARTMENT		
7. Radiator/Cooling (continued)		
Inspection Procedures:	Repair if:	Out of Service if:
f. Charge Air Cooler: 1) Check charge air cooler assembly, mounting, and plumbing for securement and condition (if equipped).	Any portion of the cooler mounting system is cracked, damaged, or has loose or missing fasteners.	Any portion of the cooler is cracked or leaking. Any plumbing connections are loose, damaged, or missing.
g. Heater Booster Pump: 1) Check the operation and condition of heater booster pump and plumbing (if equipped).	Booster pump is inoperative	Booster pump is leaking. The booster pump mounting is loose or has missing fasteners.
h. Engine Compartment Lamps (If equipped) 1) Check operation, condition, and mounting of lamps.	White lights are inoperative	Red lights are inoperative
i. EV power train components. 1) Check all components for proper mounting, securement and labeling. 2) HV high voltage cutoff switch		Loose or missing fasteners Any damaged mounting components Missing or illegible warning labels Damaged HV high voltage cutoff switch

End of Section

SCDE

Vehicle Inspection Procedures and Repair/Out of Service Criteria

Section 9 Underneath of Vehicle

<p>D. Underneath 1. Steering Note: Depending on the style of vehicle, some of the items in this section may be inspected while performing the engine compartment inspection.</p>		
<p align="center">Inspection Procedures:</p>	<p align="center">Repair if:</p>	<p align="center">Out of Service if:</p>
<p>a. Column:</p> <ol style="list-style-type: none"> 1) Check steering column outside vehicle for up and downplay (parallel to shaft), side to side play (perpendicular to shaft), and for proper mounting. 2) Column shaft and hardware. 3) Column U-joints or flexible coupling (as equipped). 4) Coupling at gear box. 	<p align="center">(Continued on Second Page)</p>	<p>Side to side play in steering column or up and downplay is excessive.</p> <p>Column assembly mounting (including floor mounting plate) or fasteners are loose.</p> <p>Steering column U-joint (if equipped) is loose, damaged, or noisy after lubrication.</p> <p>Any column U-bolt, pinch bolt, shear pins, or other column fasteners, or input shaft coupling is loose, damaged, or missing.</p> <p>Column U-joint (if equipped) is loose, damaged, or noisy after lubrication.</p> <p>Flexible coupling, if equipped (rag joint) has loose or missing fasteners, damaged flexible disc, or elongated holes.</p> <p>Splines are worn or damaged.</p>

Figure 1 - Column with Yoke or U-Joint Typical

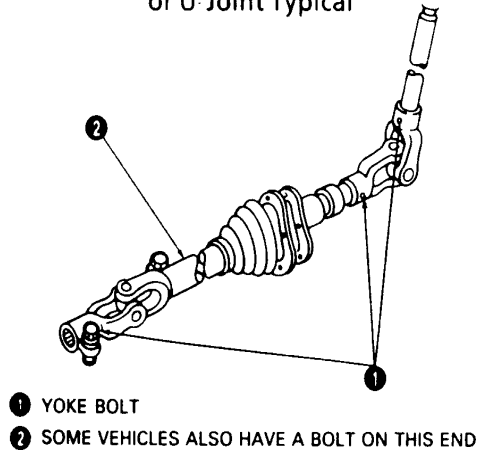
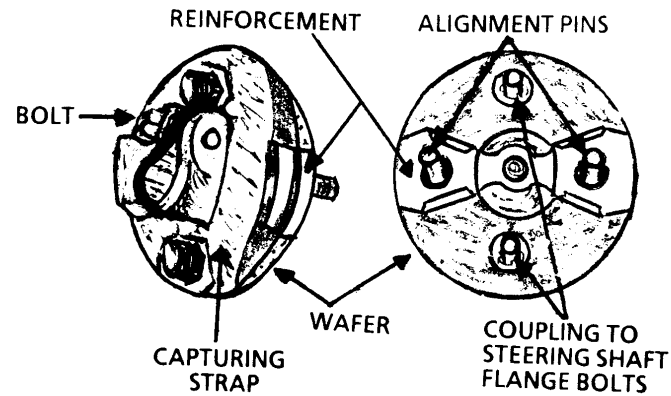
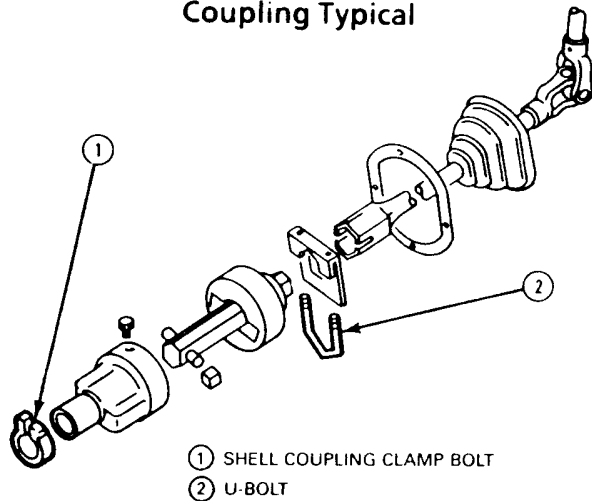

Figure 2 - Typical Flexible Type Steering Coupling



(rag joint)

Figure 3 - Column with Shell Coupling Typical



TIGHTENING STEERING COLUMN JOINT BOLTS

WARNING -FAILURE- TO MAINTAIN THE STEERING SYSTEM IN PROPER CONDITION CAN CAUSE REDUCED STEERING ABILITY RESULTING IN PERSONAL INJURY AND PROPERTY DAMAGE.

As good maintenance practice, it is recommended that steering column joint bolts be checked for tightness every 80,000 km (50,000 miles) or annually, whichever occurs first. **DO NOT OVER TIGHTEN.**

D. Underneath
1. Steering(continued)

NOTE: b – g, Steering Gear Box and other external components will be checked using the following procedure:

- 1) Vehicle should be on ground (not suspended).
- 2) With engine running have assistant move steering wheel back and forth repeatedly to load steering components.
- 3) Visually observe the following external steering and related suspension and frame components for looseness while assistant works steering (also see specific procedures under each component).
- 4) Have the assistant carefully operate the steering to full left and right turn and check for power assist pop-off and steering stops.
- 5) As a follow-up to the above steering check, also perform a visual and hands-on check of each of the listed components.

Inspection Procedures:	Repair if:	Out of Service if:
<p>b. Steering Gear Box and Mounting:</p> <p>1) Check mounting, condition, and tightness of steering gear box, and check frame, frame braces, and associated rivets or fasteners for looseness and condition.</p>	<p>The steering gear box is damp at or near seals showing signs of seepage, but no visible fluid is observed.</p>	<p>Steering gear box is loose on frame, or fasteners, or lock tabs are loose or missing.</p> <p>Mounting holes have visible cracks or are elongated.</p> <p>The steering gear box has any visible leaks.</p> <p>Any up-down or side to side motion of either shaft is observed (bearing or bushing wear).</p> <p>There is any binding in the steering gear box.</p>
<p>c. Pitman Arm:</p> <p>1) Check the pitman arm for looseness or misalignment at sector shaft splines and looseness at all joints. Check looseness of pinch bolt and fasteners and condition of pitman arm.</p>	<p>Pitman arm grease fitting (if originally equipped) is loose or missing.</p> <p>(Continued on Next Page)</p>	<p>Any play is observed between pitman arm and sector shaft.</p> <p>Pinch bolt at sector shaft is loose or missing.</p>

D. Underneath 1. Steering(continued)		
Inspection Procedures:	Repair if:	Out of Service if:
c. Pitman Arm: (continued)		<p>Pitman arm to sector shaft timing marks are misaligned.</p> <p>Pitman arm ball-joint (if equipped) has any play.</p> <p>Pitman arm ball-joint (if equipped) has loose or missing nut, or cotter pin is missing.</p> <p>Pitman arm is cracked or damaged.</p>
d. Drag Link: (if equipped) 1) Check the drag link ends, shaft, and fasteners for looseness and condition.	<p>Any drag link end grease fitting (as equipped) is loose, or missing, or will not take grease.</p> <p>Drag link end boot is damaged or missing.</p> <p>Drag link needs lubrication.</p> <p>(Continued on Next Page)</p>	<p>Drag link ball stud is loose in pitman arm or upper steering arm.</p> <p>Any nut is loose or missing, or cotter pin is missing.</p> <p>The drag link shaft is damaged or bent.</p> <p>Drag link end has any axial play.</p> <p>Adjustable (length) drag link has loose clamp or damage to the threads or has any movement or play in the shaft.</p> <p>Any drag link that is installed improperly.</p>

D. Underneath 1. Steering(continued)		
Inspection Procedures:	Repair if:	Out of Service if:
e. Steering Arm 1) Check upper steering arm (Ackerman arm) and left and right-side lower steering arms for securement and condition.		Any steering arm has been bent, cracked, or damaged. Any steering arm attachment point is loose, or any fasteners or cotter pin is missing.
2) Check condition and securement of steering stops and lock nuts.		Either the steering stop or lock is loose, damaged, or missing.
f. Tie Rod and Ends 1) Check tie rod ends, tie rod, dust boots, and clamps or fasteners (as equipped) for looseness, damage, and condition.	Tie rod end dust boot is cut, damaged, or missing. Tie rod end needs lubrication. Any tie rod end grease fitting is loose, or missing, or will not take grease.	Tie rod clamps, fasteners, or cotter pins are stripped, missing, or loose. Any clamp (as equipped) is mispositioned. Any tie rod or end is cracked or damaged. Any tie rod is bent, cracked, broken or threads are damaged in any way. Any tie rod end has any play. Tie rod end ball stud is loose in steering arm or idler arm.
	(Continued on Next Page)	

D. Underneath 1. Steering(continued)		
Inspection Procedures:	Repair if:	Out of Service if:
g. Idler Arm: 1) Check idler arm assembly (as equipped) for looseness, damage, and condition.	The idler arm needs lubrication. The idler arm grease fitting is loose, or missing, or will not take grease.	Any idler arm fasteners are loose or missing. Idler arm is cracked, or damaged, or cotter pin is missing. Idler arm has any play
h. Alignment: 1) Check for any obvious or abnormal front tire wear.	Any front tire wear indicates an alignment problem.	

TIRE WEAR

Uneven Tire Wear

The following conditions may cause spotty or uneven wear.

- Unequal caster or camber
- Bent suspension parts
- Out of balance wheels
- Out of round brake drums
- Brakes drag
- Other mechanical conditions

Locate the mechanical condition that causes uneven wear.

Correct the condition.

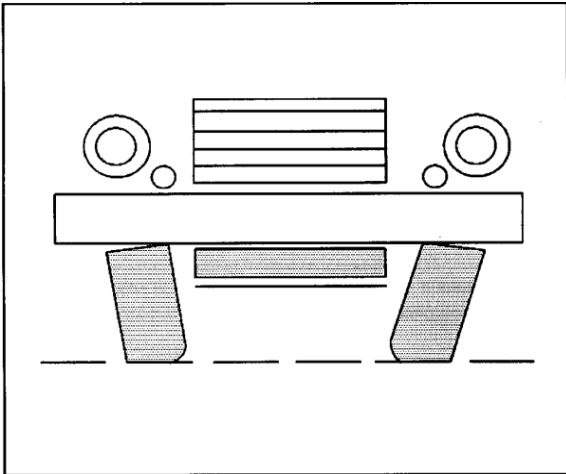

Misalignment Wear

Too much toe in or toe out on the front axle tires causes misalignment wear. The tires revolve with a side motion, which scrapes off the tread rubber.

Misalignment Wear (continued)

The scraping action against the face of the tire causes a small featheredge of rubber to appear on one side of the tread. This feathering is an indication of misalignment.

If the misalignment is severe, the rubber will be scraped off both tires. If the misalignment is slight, only one tire will be affected. In order to correct misalignment, adjust the toe in or verify that the entire front-end alignment settings are correct. Refer to *Front Toe Adjustment* in Front Wheel Alignment.

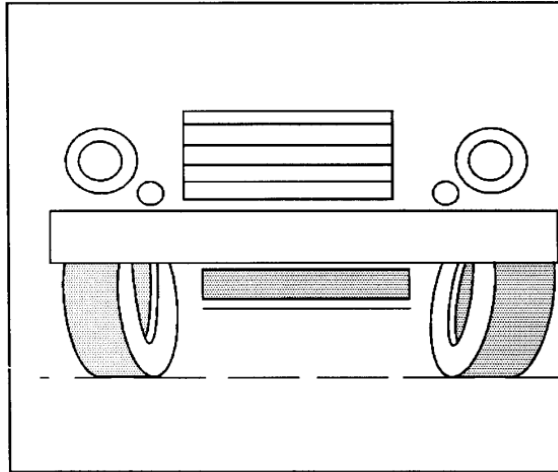

Side Wear

Side wear may be caused by the following conditions:

- Incorrect wheel camber
- Under-inflation

Side Wear (continued)

- High cambered roads
- Excessive cornering speed

Incorrect wheel camber and under-inflation are the most common causes of side wear.

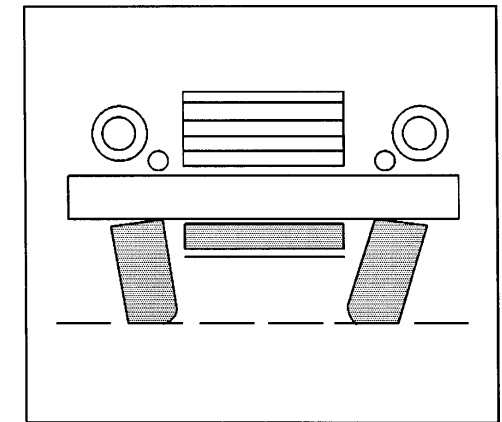
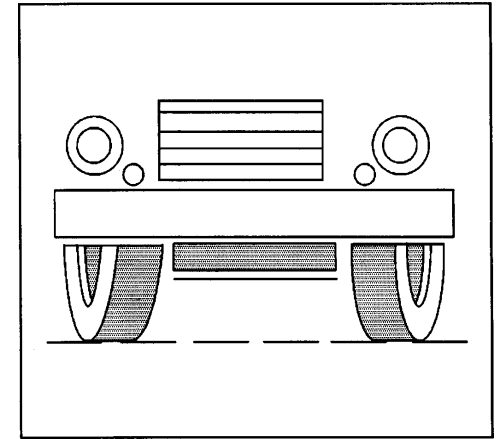

D. Underneath 2. Frame		
Inspection Procedures:	Repair if:	Out of Service if:
a. Vehicle frame: 1) Check frame rails, extensions, modular sections, cross-members, braces, gussets, liners, and any and all fasteners for damage, condition and mounting.		Frame, frame braces, and associated rivets or fasteners are loose, damaged, or missing. Frame, extensions, liners, or modular sections are damaged, cracked, or broken. Frame braces or cross-members are damaged, cracked, or broken. Rivets or other fasteners at frame braces or cross-members are loose or missing. Any axle or suspension component is loose beyond specifications prescribed elsewhere in this manual. Any unauthorized modifications (welding, drilling, etc.).
D. UNDERNEATH 3. Front Suspension		
a. Wheel Bearings: During annual inspection 1) Inspect front wheel bearings and related components for condition and proper adjustment of bearings. Grasp tire and attempt to rock wheel to check for movement. NOTE: It is important to correctly identify the source of any play. To determine if the play is in wheel bearings, have an assistant fully apply brakes while rechecking play. If movement disappears with brakes applied, then play was in wheel bearings.	There is minor seepage of grease around dust cover. Dust cover fasteners are missing or loose	Any noise, binding, or roughness is discovered in bearings. Wheel bearing, end play exceeds manufacturer's specifications (maximum of .005" in and out play measured at bearing hub). There is leaking or dripping of grease or oil around dust covers or dust cover is damaged or missing.

D. UNDERNEATH 3. Front Suspension (continued)		
Inspection Procedures:	Repair if:	Out of Service if:
b. I-Beam: 1) Inspect I-beam axle assembly		I-beam has been cut, modified, or damaged. There is any bluing or other evidence that I-beam has been heated.
c. King Pins: During annual inspection 1) Inspect king pin assemblies for condition and play as follows: Grasp tire at top and attempt to move the wheel assembly in and out. NOTE: Wheel bearings must be adjusted properly.	One locking pin (draw key) is loose (dual). End cap O-rings or bolts are loose or missing.	Locking pin (draw key) is backing out, loose (single, both for dual), or missing. King pin movement is more than 1/4 inch measured at the outside edge of tire.
2) Preliminary inspection of thrust bearings, visually inspect thrust bearing area for uneven gap, improper installation, wear, or damage. If the play is beyond specifications, wear may be king pin, axle eye, and/or king pin bushings.		Vertical (up and down) play in king pin assembly is greater than .030", and/or thrust bearing is damaged or missing. If the side play at outside edge of tire is greater than 1/4 inch.

D. UNDERNEATH 3. Front Suspension (continued)		
Inspection Procedures:	Repair if:	Out of Service if:
<p>d. Shackles:</p> <p>1) Inspect the condition of shackles, spring hangers, and pinch bolts.</p> <p>NOTE: Shackle types vary from manufacturer and year models. Bolted, pinned, pinch pinned, combination etc.</p>		<p>Any front spring shackle or hanger is cracked or broken.</p> <p>Any front spring shackle or hanger has significant side wear at spring eye.</p> <p>Any front spring shackle or hanger is worn, or pinch bolt is stripped or missing, so that spring pin cannot be clamped tightly.</p> <p>Any front spring or shackle eye bolt is loose, worn, broken, damaged or missing.</p>
<p>e. Spring Mounts</p> <p>1) Inspect spring mount bracket(s) for condition and securement.</p>		<p>Any front spring mount is broken or cracked.</p> <p>Any front spring mount-to-frame fastener is loose or missing.</p> <p>Frame is cracked at any spring or shock mounting location.</p>
(Continued on Next Page)		

D. UNDERNEATH		
3. Front Suspension (continued)		
Inspection Procedures:	Repair if:	Out of Service if:
<p>f. Pins and Bushings</p> <p>1) Inspect pins and bushings as follows: Inspect front spring pins and bushings for wear and lubrication. Check for wear with front axle loaded; look for off center spring eye, rubbing shackle, or non-symmetric joint.</p> <p>NOTE: Any questionable condition is found, jack front of bus up and identify source of play or movement.</p>	<p>Inner sleeve or rubber bushing type spring pin assembly(ies) is worn through, or rubber bushing is excessively worn (rubber is compacted or deteriorated, resulting in free play between rubber and spring eye or inner sleeve).</p>	<p>Total free play (up and down) of pins and bushings exceeds 1/4 inch.</p> <p>Any pin is loose, damaged, or worn, or cannot be properly clamped by pinch type shackles. On vehicles equipped with bolt instead of pin, bolt is loose, damaged or worn or the nut is not a locking type or is missing.</p> <p>Pin is cutting into spring, shackle, or mount.</p>
<p>g. A-Frames and Bushings: (upper and/or lower control arms, struts)</p> <p>1) Inspect A-frames and bushings for condition and securement.</p>	<p>Rubber bushing(s) are split, badly deteriorated or badly extruded from suspension joints.</p>	<p>Rubber bushing(s) is missing.</p> <p>Any A-frame, control arm, or strut assembly is bent, missing, broken, or any fasteners or U-bolt(s) are loose or missing.</p> <p>Any A-frame, bushing, or pivot arm has more than .050" free play at pivot point.</p> <p>Mounting assemblies are not secure.</p>
(Continued on Next Page)		

D. UNDERNEATH 3. Front Suspension (continued)		
Inspection Procedures:	Repair if:	Out of Service if:
h. Ball Joints: 1) Inspect ball joint(s) for condition, securement, and lubrication.	Zerk (grease) fitting is missing or damaged.	Any ball joint has play. Any ball joint nut is loose or missing, or cotter pin is missing. Ball joint to A-frame mounting is cracked or loose or has been welded.
i. U-Bolts: 1) Inspect spring U-bolts for condition and securement.		There are rust underneath U-bolt nuts indicating possibility of looseness. Any U-bolt, seating plate, shock mount bracket, or nut is loose or missing, cracked, or stripped.
j. Shocks 1) Inspect shocks for condition and securement.	There is wetness around shock body due to leaking shock fluid. Any shock mounting or fastener is loose.	Any shock or mount is missing, cracked, or broken.

D. UNDERNEATH 3. Front Suspension (continued)		
Inspection Procedures:	Repair if:	Out of Service if:
k. Springs: 1) Inspect front springs for condition, securement, and alignment.	There are any loose, missing, broken or worn spring clips. Missing insulators between leaves. Any coil or leaf spring has weakened and causing vehicle to lean. Either the front spring saddle (if equipped) is worn out or missing. Rubber bumper is missing. Ride height not adjusted properly (air suspension).	Any leaf spring(s) is broken, cracked, or missing. Spring eye is worn or spread such that bushings are loose in spring eye. Any coil spring(s) is broken, insecurely mounted, non-OEM type or non-OEM blocks or spacers are installed. There is any misalignment of spring leaves or other evidence that the center pin is loose or broken. Either front coil or leaf spring is worn so that rubber frame bumper is damaged or worn due to frequent bottoming of front suspension. Any alignment wedge is loose or damaged. On any air bag type spring assembly, air bag is damaged or leaking. Any problem with ride height control valve other than adjustment.
l. Anti roll bar/Sway bar (If equipped) 1) Inspect for mounting and condition.	Rubber mounting bushings are cracked, compressed or deteriorated to the point of allowing movement of bar.	Bar is bent, broken or missing. Any mounting hardware is broken or missing. Any rubber bushings or grommets are missing.
m. Wheel Seals 1) Check for condition and leakage.		Either wheel seal is damaged or leaking.

D. UNDERNEATH		
4. Brakes		
Inspection Procedures:	Repair if:	Out of Service if:
<p>a. Brake Hoses</p> <p>1) Inspect flexible brake hoses for condition, securement, and routing.</p>	<p>Separator bracket on dual hoses loose or out of position.</p>	<p>Any brake flex hose or connection is leaking fluid or air pressure.</p> <p>Any brake flex hose is kinked, cracked, collapsed, bulging, has damaged plies or cord, or is damaged below outer covering.</p> <p>Any brake flex hose supporting brackets are damaged or have loose fasteners.</p> <p>Any brake flex hose is rubbing on or routed against other components.</p> <p>Any brake hose fittings are damaged or rusted so as to weaken the crimp.</p>
<p>b. Lines:</p> <p>1) Inspect air and hydraulic brake lines for routing, securement, and condition.</p>	<p>The brake line bracket(s) or securement system is loose or missing and line is not in contact with any other component.</p>	<p>Any brake line is bent, crimped, or damaged restricting or leaking air pressure or hydraulic fluid.</p> <p>Any brake line or connection is leaking air pressure or hydraulic fluid.</p> <p>Any brake line is rubbing on other components or is abraded.</p> <p>Any brake line is not OEM material, size, or type.</p>
(Continued on Next Page)		

D. UNDERNEATH		
4. Brakes		
Inspection Procedures:	Repair if:	Out of Service if:
<p>c. Chambers:</p> <p>1) Inspect brake chamber assembly(ies) for securement, condition, and proper size.</p> <p>Note: Chamber should be OEM type</p>	<p>Any missing or damaged spring brake caging bolts.</p>	<p>Any brake chamber mounting bracket is cracked, bent, or broken.</p> <p>Any brake chamber or mounting fastener is damaged or loose.</p> <p>Chamber is not OEM type</p> <p>Any leak is detected in the chamber.</p> <p>Any wear to chamber or rod (where rod exits chamber).</p> <p>Any spring brake chamber is bent, damaged or corroded and may lose containment of spring.</p>
<p>d. Slack Adjusters:</p> <p>1) Inspect slack adjusters and S-cam assemblies for wear, condition, operation, and securement.</p> <p>NOTE: Check operation of Slack Adjusters.</p>	<p>(Continued on Next Page)</p>	<p>Slack adjuster is not mounted properly, or anchor bracket is loose or damaged (Haldex).</p> <p>Any portion of slack adjuster or S-cam is missing, broken, cracked, or badly worn.</p> <p>S-cam shaft and/or S-cam bushing total wear (up and down) is greater than .030 inch.</p> <p>S-cam snap ring is broken or missing.</p>

D. UNDERNEATH		
4. Brakes (continued)		
Inspection Procedures:	Repair if:	Out of Service if:
e. Slack Adjusters: (continued)		<p>Any slack adjuster is not operating properly.</p> <p>Any slack adjuster is not adjusted properly.</p> <p>Slack adjusters are mismatched or universal type.</p>
f. Pushrods: 1) Inspect pushrod assembly(ies) for condition, securement, and alignment.		<p>Any portion of pushrod assembly (locknut, pushrod, clevis and pin, or cotter pin) is loose, missing, or damaged.</p> <p>Pushrod is rubbing against body of chamber, or the chamber is misaligned.</p> <p>The pushrod on left and right sides are not mounted in identical (same) slack adjuster location hole (same effective slack adjuster length).</p> <p>Push rod length is not the same on each side.</p>
g. Linings 1) Inspect linings / pads and foundation brake hardware for contamination, wear, damage, and securement. Minimum limits are: 10/32" for drum linings 15% for disc pads		<p>Brake lining is worn to or beyond minimum limits.</p> <p>Lining is broken, cracked, or loose on the shoe.</p> <p>The friction surface is contaminated with oil, grease, or brake fluid.</p> <p>Lining is not proper size.</p> <p>Shoe platform or web is cracked or damaged.</p> <p>There is any loose, damaged, or missing foundation brake hardware within the drum.</p>

D. UNDERNEATH		
4. Brakes (continued)		
Inspection Procedures:	Repair if:	Out of Service if:
h. Drums 1) Inspect the brake drum(s) for condition.		There is any crack (other than heat checks) in any drum. There is any grease, oil, or brake fluid on the inside of drum. The drum is not mounted securely to hub, or fasteners are loose.
i. Rotors 1) Inspect brake rotor(s) for mounting, thickness, and condition.		Rotor mounting is not secure. Rotor has cracks (other than heat checks) or other mechanical defects. The friction surface is contaminated with oil, grease, or brake fluid. Any rotor friction surface is significantly grooved or damaged.
j. Wheel Cylinders or Calipers 1) Inspect wheel cylinder(s) or caliper(s) for leaks, mounting, and condition.	Any caliper dust boot is damaged or missing.	Any wheel cylinder or caliper is not securely mounted or has loose or missing fasteners. Any wheel cylinder or caliper is leaking. There is uneven lining or pad wear, rotor or drum damage, or evidence of dragging, or other evidence that any wheel cylinder or caliper may be sticking.

D. UNDERNEATH		
4. Brakes (continued)		
Inspection Procedures:	Repair if:	Out of Service if:
k. Brake Adjustment: 1) For hydraulic drum brakes, check condition.		There is any damage or condition which prevents proper adjustment of hydraulic drum brakes.
2) For air brakes, check and record brake chamber pushrod travel at all four (4) wheel positions.		There is any damage or condition which prevents proper adjustment of S-cam. Adjusted stroke (pushrod travel) of any slack adjuster is at or beyond stroke limits in chart.
l. Air Dryer 1) Check the dryer for securement and condition.	The dryer has loose or missing mounting bolts but not in danger of falling off. The canister portion of dryer is bent or damaged but is not leaking or loose.	The dryer has loose or missing mounting bolts and is in danger of falling off. The canister portion of dryer is bent or damaged and is leaking or loose.
2) Check dryer fittings, plumbing and connections.	Electrical connection for heating element Loose or damaged. Airline to dryer has a loop or low spot (sump) that can collect water and freeze.	Any airline connection is loose or has an audible leak.
3) Check purge valve for operation and contamination. Note: There may be dampness and oil residue on and around valve. A slight leak is acceptable from valve during charging cycle or if shut down prior to purge cycle.		Valve is contaminated by solid material (desiccant, cloth, rubber, metal, etc.), which would prevent it from seating. Valve continues to leak after purge cycle.
(Continued on Next Page)		

D. UNDERNEATH		
4. Brakes (continued)		
Inspection Procedures:	Repair if:	Out of Service if:
<p>m. Brake Valves</p> <p>1) Inspect all brake system valves for securement and condition.</p>		<p>There are any audible air leaks or visible hydraulic fluid leaks from any brake valve.</p> <p>Any brake valve is not mounted securely, cracked, or damaged.</p> <p>Any valve exhaust port is obstructed.</p>
<p>n. Reservoir Mounting</p> <p>1) Inspect reservoirs (air, vacuum tanks) for securement and condition.</p>		<p>Any reservoir mounting strap or fastener is cracked, loose, or missing.</p> <p>Any leaking, damaged, or cracked tank.</p>
<p>o. Bleed Air Reservoirs</p> <p>1) With air system fully charged, check manual operation of safety relief valve.</p> <p>2) Partially open manual petcock valve on the first (wet) tank.</p> <p>3) Allow any moisture (water) or contamination to drain.</p>	<p>There is excessive moisture in the reservoir (desiccant type air dryer equipped vehicles only).</p>	<p>Safety relief valve leaks or does not release pressure.</p> <p>There is excessive sludge or oil contamination in the reservoir.</p> <p>Reservoir leaks due to corrosion or is cracked.</p>

D. UNDERNEATH		
4. Brakes (continued)		
Inspection Procedures:	Repair if:	Out of Service if:
<p>p. Hydrovac Booster</p> <p>1) Inspect booster system for securement and condition.</p>		<p>There is any visible hydraulic brake fluid leakage.</p> <p>There is any audible vacuum leakage.</p> <p>Any brake line or vacuum hose is routed subject to excessive heat or abrasion.</p> <p>Any brake line or hose is deteriorated or damaged to the point that failure could occur (cord frayed, wall thickness thin, rubber contaminated with oil, crimped, blistered, cracked, rusted or corroded crimp, etc.).</p> <p>Any brake line or hose connection is loose.</p> <p>Any booster is not mounted securely, is cracked, or damaged.</p> <p>Any vent port is not properly plumbed or is obstructed, or filter is clogged.</p>

AIR BRAKE ADJUSTMENT CHART

Chamber Type	Maximum Legal Stroke
12	1 3/8"
16	1 3/4"
24	1 3/4"
30	2"
24 Long Stroke	2"
30 Long Stroke	2 1/2"

PROCEDURE FOR MEASURING PUSH ROD TRAVEL

Brake chamber push rod travel shall not exceed those specifications relating to maximum stroke at which brakes should be readjusted. Performance of the brake push rod travel inspection should be done with the brake application air pressure in the range of 80 - 90 pounds per square inch (psi), when measuring total stroke to determine proper brake adjustment.

CAUTION: Chock wheels before commencing this inspection as vehicle emergency brake(s) must be released.

1) With brakes off, mark push rod at chamber. 2) Apply brakes, measure distance of mark from chamber.

Note: When brakes are properly adjusted and fully applied, the slack adjuster should be at an angle of 90 Degrees or greater, measured from centerline of adjuster to push rod.

BRAKES RELEASED

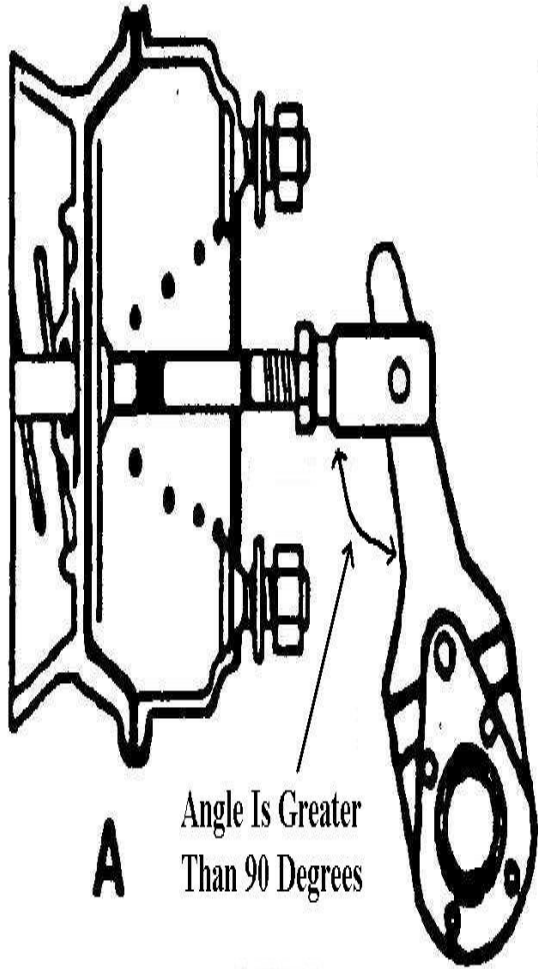

BRAKES APPLIED

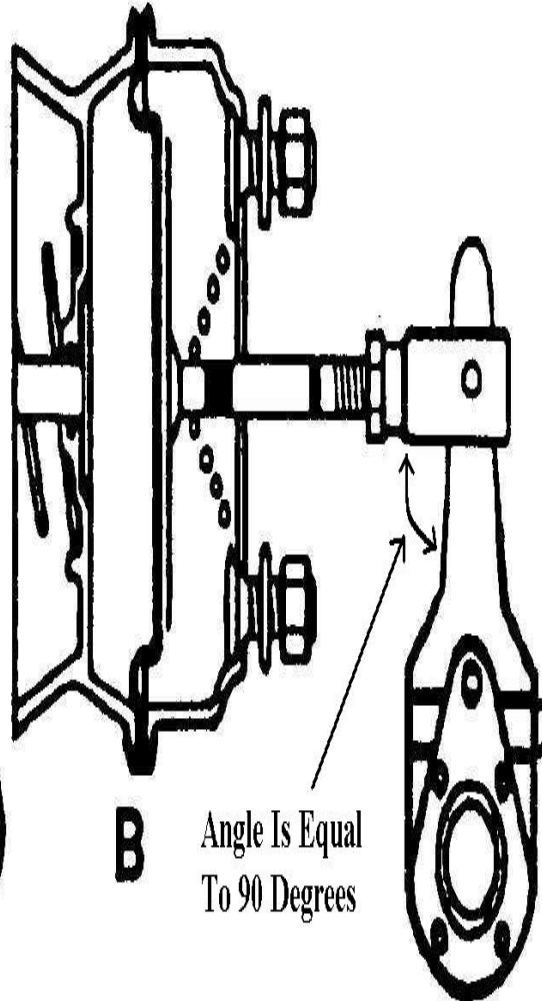

**IMPROPER INSTALLATION
OR BRAKES OUT OF
ADJUSTMENT**

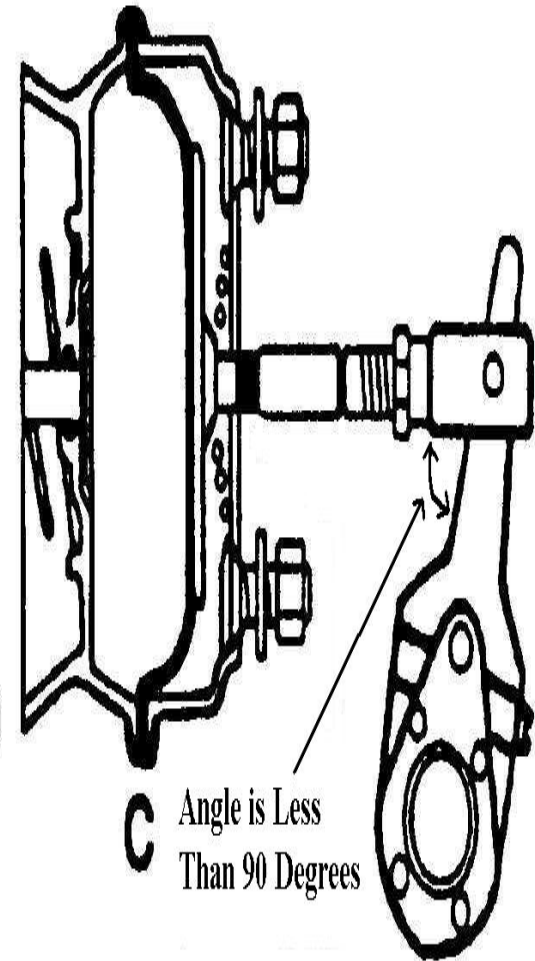

D. UNDERNEATH		
5. Mounts		
Inspection Procedures:	Repair if:	Out of Service if:
<p>a. Engine/Transmission Mounts/HV Battery</p> <p>1) Inspect engine, transmission and/or HV battery mounts for condition and securement.</p>	<p>Replace the mount if any of the following conditions exist:</p> <p>Hard rubber surface covered with heat check cracks.</p> <p>The rubber cushion separated from the metal plate of the mount.</p> <p>The rubber cushion is split through the center.</p>	<p>Any mounting fasteners are loose, missing, or broken.</p> <p>Any mount is cracked or has missing rubber cushion.</p>
<p>b. Starter Mounting</p> <p>1) Inspect starter for securement and condition. Check for presence of heat shield (if equipped).</p>	<p>Heat shield is loose or missing (if equipped).</p>	<p>Any starter mounting bolt, stud, or nut is loose, damaged, broken, or missing.</p> <p>The starter is damaged or loose.</p> <p>Heat shield looseness or damage could short positive terminal to ground or damage any other component.</p>

D. UNDERNEATH		
4. Transmission		
Inspection Procedures:	Repair if:	Out of Service if:
a. Transmission Bolts 1) Inspect transmission assembly and mounting fasteners for condition and securement.		Transmission is not mounted securely to flywheel housing. There is any external indication that any torque converter bolt(s) are loose or missing.
b. Linkage 1) Inspect transmission linkage for routing, condition, and securement.	Any linkage hardware or fasteners are loose. Dust/moisture boots on cable missing or torn.	Linkage is bent, damaged, or binding, or severely misadjusted. Any linkage hardware or fasteners are missing, or linkage is damaged to cause a sticking or binding condition.
c. Lines 1) Inspect transmission lines for securement, routing, and condition.	Any transmission line(s) is unsecured or routed subject to excessive heat or abrasion. There is any transmission line of improper type. (Continued on Next Page)	Any transmission line is crimped. Any transmission line or fitting is leaking. Any transmission line is worn or deteriorated to the point that failure could occur. (leaking)

D. UNDERNEATH		
4. Transmission(continued)		
Inspection Procedures:	Repair if:	Out of Service if:
d. Filter 1) Inspect transmission external filter assembly (if equipped) for securement and condition		Body of the transmission filter, including all hose connections, is cracked or damaged and is leaking.
e. Cooler 1) Inspect transmission cooler		Any external leak or transmission fluid in cooling system (internal leak).
f. Clutch 1. Operation a) Check pedal, linkage, clutch, and throw-out bearing for wear, slippage, and abnormal noises in the engaged and released positions.	Loose nuts and bolts. Noisy throw-out bearing. Clutch out of adjustment.	Cannot adjust clutch to specs. Excessively noisy throw-out bearing. Clutch slipping, grabbing, or has excessive chatter when engaging clutch. Binding or sticking clutch linkage or return spring. Hard to shift transmission.
b) Visually check clutch pedal pad for wear.	Worn pedal cover pad.	Missing pedal cover pad.
c) Check clutch master and slave cylinders for hydraulic leaks and operation (if equipped).		Leaking master or slave cylinder or line and/or inoperable.
(Continued on Next Page)		

D. UNDERNEATH		
4. Transmission (continued)		
Inspection Procedures:	Repair if:	Out of Service if:
g. Clutch (continued) 2. Adjustment a) Check “free play” travel of the clutch pedal. This is the first easy movement of the clutch pedal and should be no more than 1-1/2 and no less than 3/4 an inch of travel.	Free play is out of adjustment.	Clutch slips, grabs, or chatters after adjusting “free play” travel. No adjustments can be made (if it is an adjustable clutch).
D. UNDERNEATH		
7. Fluid Leaks		
a. Oil 1) Inspect engine oil leaks at all potential locations.		Any oil leak
b. Coolant 1) Inspect all potential locations for coolant leaks. 2) High voltage coolant system		Any coolant leak
c. Transmission 1) Inspect for transmission fluid leaks at all potential locations.		Any fluid leak
	(Continued on Next Page)	

D. UNDERNEATH 7. Fluid Leaks (continued)		
Inspection Procedures:	Repair if:	Out of Service if:
d. Power Steering 1) Inspect for power steering fluid leaks at all potential locations		Any fluid leak
D. UNDERNEATH 8. Fuel Tank(s)		
a. Leaks 1) Inspect fuel tank assembly for leaks. 2) LPG for any leak (smell)		There is any fuel leakage from the tank, connections, or cap. The fuel tank has any cracks. Any connection(s) are loose at the tank. Any smell of propane odor
b. Mounting 1) Inspect fuel/LPG tank mounting system and barrier (if equipped) for securement and condition.		Any portion of fuel/LPG tank mounting system (including support brackets, retaining straps, and chassis frame) is missing, loose, cracked, or broken. Any fuel/LPG tank mounting fasteners are loose or missing. Barrier assembly (if originally equipped) is damaged, insecurely mounted, or missing. Fuel/LPG tank is not OEM, been modified, or extra tank(s) have been added.
(Continued on Next Page)		

D. UNDERNEATH 8. Fuel Tank(s) (continued)		
Inspection Procedures:	Repair if:	Out of Service if:
<p>c. Hoses 1) Inspect all fuel lines, hoses, and under-bus fuel system components, for routing, securement, and condition (including vents, fill, and crossover).</p>		<p>Any fuel line or hose is unsecured or is routed subject to excessive heat or abrasion.</p> <p>Any fuel line or hose is deteriorated or damaged (including cracks or any damage which may cause potential leakage) or clamps are loose or missing.</p> <p>Any under-bus fuel system filter, water separator, or other components are insecurely mounted, cracked, or damaged.</p>
<p>d. Wiring 1) Inspect fuel tank sender unit wiring for securement, routing, and condition.</p>	<p>Any portion of sending unit wiring (including ground) or connections is unsecured or is routed subject to excessive heat or abrasion.</p>	<p>Any wiring or connection has damaged or missing insulation.</p>
D. UNDERNEATH 9. Driveline		
<p>a. Driveshafts 1) Inspect driveshafts and damper for condition.</p>		<p>Any driveshaft balancing weight (if originally equipped) is missing.</p> <p>Any driveshaft is bent or seriously dented.</p> <p>Any loose, damaged, or leaking Damper.</p> <p>There are any cracks or other damage to the driveshaft, which could cause structural failure.</p> <p>There is any foreign matter wrapped around driveshaft.</p>

D. UNDERNEATH		
9. Driveline		
Inspection Procedures:	Repair if:	Out of Service if:
b. U-Joints 1) Prior to lubrication, inspect U-joints or constant velocity (CV) joints (if equipped) for condition, phasing (alignment of joints), lubrication, and presence of all hardware.	Shaft is out of Phase. U-joints or constant velocity joints are dry of lubrication, or zerk (grease) fitting (if equipped) is missing, clogged, or inaccessible.	There is any missing hardware or fasteners in any U-joint or CV joint assembly. Any U-joint has significant cross-shaft-to-bearing cup play, or CV joint has significant play. Any U-joint or CV joint shows evidence of significant rusting of bearings. Any bearing cup is loose in yoke. Any mismatched or wrong type cup straps or bolts.
c. Yokes 1) Inspect driveshaft yokes for condition and lubrication.	Driveshaft splines are not lubricated. Dust cap on yoke is loose or missing. Zerk (grease) fitting is missing or clogged.	Any yoke has significant play in splines. Any yoke is cracked or damaged.
d. Midshaft (Midship) Bearings 1) Inspect midshaft (midship) bearings and rubber insulators for condition and securement.	Midshaft (midship) bearing rubber insulator is deteriorated, damaged, or oil soaked. Midshaft (midship) bearing support is misaligned. (Continued on Next Page)	Bearing outer race is loose in insulator, or inner race is loose on shaft. There is significant play in midshaft (midship) bearing. There is any missing or damaged hardware or fasteners in midshaft (midship) bearing or support assembly.

D. UNDERNEATH 9. Driveline (continued)		
Inspection Procedures:	Repair if:	Out of Service if:
e. Guards 1) Inspect for presence and condition of driveshaft guards (if originally equipped).	Any driveshaft guard is bent or damaged. (not rubbing)	Any driveshaft guard is missing or has loose or damaged mounting fasteners or is rubbing shaft.
f. Driveshaft Park Brake 1) Inspect driveshaft park brake assembly for condition, mounting, securement, and adjustment of linings, drum, linkage, and all other related hardware.		Lining is worn beyond allowable limits. Lining is contaminated with grease or oil. Lining is broken, cracked, or loose. Drum is cracked or has excessive heat damage or scoring of friction surface. Any actuating or mounting hardware or fastener is damaged, loose, or missing. Park brake is not adjusted per manufacturer's specifications.
D. UNDERNEATH 10. Rear Suspension		
a. Axle Housing 1) Inspect axle housing for condition and leakage.	(Continued on Next Page)	Any portion of axle housing is cracked or bent. Any portion of axle housing is leaking lubricant due to cracks, porous metal, or defective weld. There is any leakage at or around axle housing ends.

D. UNDERNEATH 10. Rear Suspension (continued)		
Inspection Procedures:	Repair if:	Out of Service if:
b. Vent 1) Inspect condition of axle housing vent.	Axle vent is not functional or is missing. Vent cap is clogged. Vent hose (if originally equipped) is cracked, clogged, or missing.	
c. Differential 1) Inspect differential assembly for condition and leakage.	Differential gasket or pinion seal is seeping.	Any external differential hardware or fasteners are loose or missing. Differential pinion yoke has end play or side play exceeding manufacturer's specifications. Pinion/yoke end nut is loose or missing. Differential gasket or pinion seals are leaking.
d. Springs: 1) Inspect rear springs for condition, securement, and alignment.	There are any loose, missing, broken or worn spring clips. Missing insulators between leaves. Any coil or leaf spring has weakened, and vehicle is leaning excessively. Either the rear spring saddle (if equipped) is worn out or missing (repair). Rubber frame bumper is missing.	Any leaf spring(s) is broken, cracked, or missing. Spring eye is worn or spread such that bushings are loose in spring eye. Any coil spring(s) is broken, insecurely mounted, non-OEM type or non-OEM blocks or spacers are installed. There is any misalignment of spring leaves or other evidence that center pin is loose or broken.
(Continued on Next Page)		

D. UNDERNEATH		
10. Rear Suspension (continued)		
Inspection Procedures:	Repair if:	Out of Service if:
<p>e. Springs: (continued)</p> <p>1) Inspect rear springs for condition, securement, and alignment.</p>	<p>Ride height not adjusted properly (air suspension).</p>	<p>Either coil or leaf spring is worn so that rubber frame bumper is damaged or worn due to frequent bottoming of rear suspension.</p> <p>Any alignment shim or wedge is loose or damaged.</p> <p>On any air bag type spring assembly, air bag, or air lines and valving is damaged or leaking. Any problem with ride height control valve other than adjustment.</p> <p>Air ride pivot pins and bushings are loose.</p>
<p>f. Anti-roll bar/Sway bar (If equipped)</p> <p>1) Inspect for mounting and condition.</p>	<p>Rubber mounting bushings are cracked, Compressed or deteriorated to the point of allowing movement of bar.</p>	<p>Bar is bent, broken or missing.</p> <p>Any mounting hardware is broken or missing.</p> <p>Any rubber bushings or grommets are missing.</p>
<p>g. U-Bolts</p> <p>1) Inspect spring U-bolts for condition and securement.</p>	<p>Any U-bolt is misaligned.</p>	<p>There is rust underneath U-bolt nuts indicating possibility of looseness.</p> <p>Any U-bolt is cracked, stripped, broken or missing.</p> <p>Any U-bolt is not OEM size, type and/or design.</p> <p>Any U-bolt seating plate, shock mount bracket, or nut, is loose, missing, cracked, or stripped.</p>
(Continued on Next Page)		

D. UNDERNEATH		
10. Rear Suspension (continued)		
Inspection Procedures:	Repair if:	Out of Service if:
<p>h. Shocks</p> <p>1) Inspect rear shocks for condition and securement.</p>	<p>There is any wetness around shock body due to leaking shock fluid.</p> <p>Any shock mounting or fastener is loose.</p>	<p>Any shock or mount is cracked, broken or missing.</p>
<p>i. Shackles</p> <p>1) Inspect rear suspension shackles, spring hangers, and hanger pinch bolts for condition and securement.</p> <p>NOTE: Shackles types vary from manufacturer and year models. Bolted, pinned, pinch pinned, combination etc.</p>		<p>Any rear spring shackle or hanger is cracked or broken.</p> <p>Any rear spring shackle or hanger is worn to the point, or pinch bolt is stripped or missing, so that spring pin cannot be clamped tightly.</p> <p>Any rear spring shackle or hanger has significant side wear at spring eye.</p> <p>Any rear spring or shackle eye bolt is loose, worn, broken, damaged or missing.</p>
<p>j. Pins and Bushings</p> <p>1) Inspect rear spring pins and bushings for wear and lubrication. (same as front) For other types of pin and bushing configurations, see manufacturer's Service Manual.</p> <p>NOTE: If any questionable condition is found, jack rear of bus up and identify source of play or movement.</p>	<p>Inner sleeve or rubber bushing type spring pin assembly(ies) is worn through, or rubber bushing is excessively worn (rubber is compacted or deteriorated, resulting in free play between rubber and spring eye or inner sleeve).</p>	<p>Pin is cutting into spring, shackle, or mount.</p> <p>Any pin is loose, damaged, or worn, or cannot be properly clamped by pinch type shackles. On Vehicles equipped with bolt instead of pin, bolt is loose, damaged or worn or the nut is not a locking type or is missing.</p>

D. UNDERNEATH		
10. Rear Suspension (continued)		
Inspection Procedures:	Repair if:	Out of Service if:
k. Hangers 1) Inspect hangers for mounting and condition.		Any spring hanger or bracket is cracked or broken, or any mounting fastener is loose or missing.
l. Control arms/rods 1) Inspect rear axle control, torque, stabilizer, etc. arms/rods (if equipped) for condition and mounting.	Rubber mounting bushings are cracked, Compressed or deteriorated to the point of allowing movement of bar. (Continued on Next Page)	Bar is bent, broken or missing. Any mounting hardware is broken or missing. Any rubber bushings or grommets are missing.
m. Seals 1) Inspect rear wheel seals and gaskets for condition and leakage.		Either rear wheel seal is damaged or leaking. Any axle flange stud or nut is loose or missing.
D. UNDERNEATH		
11. Body Securement and Structure		
a. Body Mounts 1) Inspect for securement and condition of all body mounts, chassis cowl mounts, and frame pads. Body mounts include any J-bolt, U-bolt, shear bolt or clamp type mounts used to secure body to the chassis frame.	Padding between frame rails and floor sills is missing or grossly misaligned. Any isolators (donuts) are split, cracked or deteriorated so as not to be effective. (Continued on Next Page)	Any combination of the following conditions found for 25% or more of the body mounts: (<u>if less than 25% repair or note</u>) Originally installed body mount or cowl mount is missing. Body mount has missing hardware. Body mount is cracked, damaged or stripped. Body mount is loose or misaligned. Isolators (donuts) are missing.

D. UNDERNEATH		
11. Body Securement and Structure (continued)		
Inspection Procedures:	Repair if:	Out of Service if:
b. Floor 1) Inspect the condition of floor structure, sills, and braces.	There are any minor cracks in floor sills or braces or in welds.	There are holes or cracks in floor sheet metal creating an opening to the passenger compartment. Entire cross section of any floor sill or brace is broken. There is any broken weld or mounting of a floor sill or brace resulting in complete separation more than one (1) foot in length.
c. Outriggers 1) Inspect body outriggers and hardware for condition and securement.	Any installed (as required by manufacturer) outrigger is missing. Body outrigger is cracked or has loose or missing hardware.	
d. Braces 1) Inspect for condition and securement of all chassis and body braces.	<p align="center">(Continued on Next Page)</p>	Any bumper brace is broken, cracked, or missing. There is any cracked brace underneath the body.

D. UNDERNEATH		
11. Body Securement and Structure (continued)		
Inspection Procedures:	Repair if:	Out of Service if:
e. Skirts 1) Inspect body skirts and gussets for securement and condition.	Body skirt, brace, or gusset has cracked or broken sheet metal or mounting points.	Any skirt, brace, or gusset is bent, damaged or deformed to the point of being hazardous.
D. UNDERNEATH		
12. Exhaust Systems		
a. Exhaust Leaks: 1) With engine running and at operating temperature, inspect exhaust system for leaks, condition, and securement.		There is any leakage, which is audible or can be felt around any portion of the exhaust system including manifold(s), pipe sections, or any junction. There is any physical damage to the exhaust system that is adding restriction or back pressure but no leak.
b. Mounting 1) Inspect mounting of the exhaust system	There is any exhaust system hanger, which is not securely mounted. There is any originally installed exhaust hanger, which is missing, broken, or detached from exhaust system or frame mounting point. Any exhaust pipe or clamp is loose.	Any clamp is missing.
c. Mufflers 1) Inspect for presence and condition of the muffler.	There is physical damage to the muffler. (Continued on Next Page)	The muffler is leaking. The muffler is missing.

D. UNDERNEATH 12. Exhaust Systems (continued)		
Inspection Procedures:	Repair if:	Out of Service if:
d. Tailpipe 1) Inspect the condition of tailpipe.	The tailpipe extends more than 2 inches beyond the bumper.	The tailpipe is leaking. There is any physical damage to tail pipe that is adding restriction or back pressure. The tailpipe does not extend at least to the edge of the rear bumper or the rearmost OEM mounting position. Exhaust discharges under occupant compartment.
e. Catalytic converter: 1) Inspect for presence and condition of the converter if applicable.		The converter is leaking. The converter is missing. There is any physical damage to the converter that is adding restriction or back pressure
f. Diesel Particulate Filter: 1) Inspect for presence and condition of DPF/SCR if applicable. 2) DEF tank and lines		The DPF/SCR/DEF damaged or leaking. The wiring is damaged, not properly secured/routed, not properly insulated Lines are damaged, leaking or not properly secured
g. Exhaust Shielding 1) Inspect for presence and condition of all OEM exhaust installed shielding.		Shielding is damaged, not properly secured

<p>D. UNDERNEATH 13. Wheels and Tires</p>		
<p>a. Tread Depth 1) Visually inspect and measure any tire that is questionable (including spare if equipped).</p> <p>NOTE: Measurement shall be taken at the major tread groove exhibiting the greatest amount of wear. Measure at three (3) points spaced equally around the circumference of the tire in the same groove. Do not measure at wear bars.</p>		<p>Measured tread depth of either front tire (virgin carcass) at three measured points is less than 4/32 inch.</p> <p>The measured tread depth of either rear tire at three measured points is less than 3/32 inch.</p>
<p>b. Pressure 1) Visually inspect tires for obvious inflation problems (including spare if equipped).</p>		<p>Any tire that is obviously low in pressure or flat.</p> <p>Any tire that has an audible or visible leak.</p>
<p>c. Alignment 1) Inspect tires for evidence of proper alignment.</p>	<p>Any tire is feather-edged, cupped, or has uneven tread wear.</p>	<p>Tires/wheels are grossly misaligned, affecting steering control.</p>
<p>d. Damage 1) Inspect for damage to wheels and tires. (including spare if equipped)</p> <p>NOTE: Refer to Tire and Rim Manufacturer's Association manual for correct procedures in demounting and mounting of tires and rims.</p>	<p>Any valve cap is missing or not metal.</p> <p>Any valve stem is damaged, or mis located so that tire cannot be filled with air.</p> <p>(Continued on Next Page)</p>	<p>There are any cuts, abrasion, or other damage to tire sidewall resulting in exposed or damaged cord.</p> <p>There is any evidence of separation, bulges (other than normal manufacturer bulge), or other damage within the carcass of the tire.</p> <p>There are any cracks, which run around the bead or sidewall of the tire.</p> <p>There is anything wedged between the dual rear wheels.</p> <p>There is foreign material in the tire tread, which could cause damage or loss of air pressure.</p>

D. UNDERNEATH		
13. Wheels and Tires (continued)		
Inspection Procedures:	Repair if:	Out of Service if:
<p>e. Damage (continued)</p> <p>1) Inspect for damage to wheels and tires. (Including spare if equipped)</p>		<p>On a retread there is any separation of the tire tread from the tire carcass, which could result in tire or tread failure.</p> <p>There is any damage to the lock ring assembly or lock ring groove of a multi-piece rim, including rust or corrosion, which could cause the lock ring not to seal fully.</p> <p>There are any cracks or breaks at the lug holes or any other part of a rim or cast spokes.</p> <p>There are any dents or bends in a rim, which could result in failure of the rim or separation of the tire from the rim.</p>
<p>f. Matching</p> <p>1) Inspect for matching of tire construction, design, size, and load rating on each axle.</p>		<p>There is mismatching of inner and outer dual tire diameter greater than 3/8 inch.</p> <p>There is any tire marked for other than highway use.</p> <p>Any tire is not of proper type, size, and minimum load rating. All tires on an axle are not of same type (e.g., lug or rib).</p> <p>All tires on an axle are not the same size.</p> <p>Any tire is below minimum load rating.</p> <p>Any front tire is recapped.</p>

D. UNDERNEATH 13. Wheels and Tires (continued)		
Inspection Procedures:	Repair if:	Out of Service if:
g. Wheel Hardware 1) Inspect for presence, type, condition, and securement of all wheel hardware.		There is evidence of slippage of wheel assembly on cast spoke hub. Stud holes are elongated. Any wheel nut, stud, or clamp is loose, or there is rust or corrosion indicating possible looseness. Any wheel, nut, stud, or clamp is broken or missing.
2) Check for proper spacing of rear dual wheels and tires (proper spacer width).		Any improper spacer is installed between dual wheels.

End of Section

Index for SCDE Vehicle Inspection Procedures/Criteria

Alarms

Backup	7-6
Child Safety	7-11

Axles

Front Bearings	9-9
Front I-Beam	9-10
Front Seals	9-14
Rear Differential	9-32
Rear Housing	9-31
Rear Housing Vent	9-32
Rear Seals	9-35

Body

Braces	9-36
Bulkhead Seals	6-44
Bumpers	7-15
Cleanliness Exterior	7-19
Cleanliness Interior	6-45
Crossing Arm	7-11
Damage	7-15
Floor Inside	6-44
Floor Underneath	9-36
Grab Rails	6-2
Interior Paneling	6-45
Interior Wiring	6-44
Lettering Exterior	7-16
License Plate	7-7
Loose Objects Inside	6-46
Mounts	9-35
Outriggers	9-36
Paint	7-15
Reflective Markings	7-16
Reflectors	7-8

Body (continued)

Service Door	6-27
Skirts	9-37
Stepwell	6-2
Stop Arm	7-10
Sun Visor	6-43
Wheelchair Lift/Securement	6-46/47
Windshield Steps/Handles	7-18

Brakes

Adjustment	9-19
Drums	9-18
Brake, Lines/Hoses	9-15
Linings	9-17
Park Driveshaft	9-31
Rotors	9-18
Valves	9-21
Air Adjustment Chart	9-23
Air Chamber	9-17
Air Chamber Pushrods	9-18
Air Compressor	8-11
Air Dryer	9-20
Air Gauge	6-11
Air Low Warning	6-14
Air Park Brakes	6-13
Air Reservoirs	9-20
Air Slack Adjusters	9-16
Hydraulic Cylinder/Caliper	9-18
Hydraulic Fluid	8-2
Hydraulic Pump	8-10
Hydraulic w/Electric Pump	6-18
Hydraulic w/Vacuum Assist	6-18
Hydrovac Booster	9-21

Driveline

Driveshaft	9-29
Guards	9-31
Midshaft Bearings	9-31
U-Joints	9-30
Yokes	9-30

Electrical

Alternator	8-12
Battery	7-12
Battery Cables	7-13
Battery Hold Down	7-12
Battery Terminals	7-12
Battery Tray	7-13
Electrical Compartment	7-14
Engine Comp. Wiring	8-13
Horn	6-28
Starter	8-12
Starter Mounting	9-24

Emergency Equipment/Exits

Body Fluid Kit	6-4
Body Fluid Kit Supplies	6-6
Door, Inside	6-40
Door, Outside	7-17
Exit Buzzers	6-41
Exit Labeling/Pad	6-40
Fire Extinguisher	6-2
First Aid Kit	6-3
First Aid Kit Supplies	6-6
Push Out Window	6-40
Stop The Bleed Kit	6-40

Revised 02-2025

Index for SCDE Vehicle Inspection Procedures/Criteria

Emergency Equip/Exits (Cont.)

Reflective Triangles	6-5
Roof Hatches	6-40
Safety Equipment Trucks	7-19

Engine & Accessories

Accelerator	6-9
Air Cleaner	8-9
Belt Inspection	8-5
Belt	8-3
Belt Tension	8-7
Coolant	8-3
Coolant Leaks	9-27
Coolant Recovery Tank	8-14
Coolant Reservoir	8-14
Cover/Dog House	6-45
Fan	8-11
Fan Shroud	8-14
Fast Idle Switch	6-10
Gauges	6-10
Hood	7-18
Hoses	8-8
Ignition Switch	6-9
Mounts	9-24
Oil	8-2
Oil Leaks	9-27
Performance	8-9
Pulley Inspection	8-6
Radiator Cap	8-14
Radiator Mounting	8-14
Shutdown	6-9
Warning Lights/Buzzer	6-12

Engine & Accessories (Cont.)

Water Pump	8-11
------------	------

Exhaust System

Catalytic Converter	9-38
Leaks	9-37
Mounting	9-37
Mufflers	9-37
Tailpipe	9-38

Fuel System

System/Lines	8-13
Tank Hoses	9-29
Tank Leaks	9-28
Tank Mounting	9-28
Tank Wiring	9-29

Heater/Ventilation

Defroster	6-25
Driver Fan	6-26
Heater	6-25

Information Sources

Communications Equip.	6-43
Decals Inside	6-8
Insurance Card	6-7
Registration Card	6-7

Lights

Amber Revolving	7-7
Clearance/Marker/ID	7-6
Backup	7-5
Brake	7-4

Lights (Continued)

Dash	6-11
Hazard	7-4
Headlights	7-2
License Plate	7-7
Park	7-7
Pupil Warning	7-8
Strobe	7-8
Tail	7-6
Turn Signals	7-3

Mirrors

Mirror, Adjustment Chart	6-33
Application Chart	6-31
Convex	6-30
Interior	6-31
Rear View	6-29
Exterior	7-14

Seats

Bottom	6-38
Driver	6-35
Flip up	6-38
Frames	6-36
Infant Seating	6-38
Modesty Panel/Stanchion	6-38
Mounting	6-36
Pads/Safety Barriers	6-37
Upholstery Damage	6-37

Index for SCDE Vehicle Inspection Procedures/Criteria

Steering

Alignment	9-7
Ball Joints	9-13
Column Inside	6-33
Column Joints	9-2
Column Outside	9-2
Drag Link	9-5
Fluid	8-2
Fluid Leaks	9-28
Gear/Mounting	9-4
Idler Arm	9-7
King Pins	9-10
Pitman Arm	9-4
Pump	8-10
Steering Arm	9-6
Steering Arm Illustration	9-3
Tie Rod/Ends	9-6
Wheel	6-34
Wheel Play Chart	6-34
Wheel Play/Lash	6-33

Suspension

A-Frames/Bushings	9-12
Frame Vehicle	9-19
Front Pins/Bushings	9-12
Front Shackles	9-11
Front Shocks	9-13
Front Spring	9-14
Front Sway Bar	9-14
Front U-Bolts	9-14
Rear Control Arms/Rods	9-35

Suspension (Continued)

Rear Pins/Bushings	9-34
Rear Shackles	9-34
Rear Shocks	9-34
Rear Spring	9-32
Rear Sway bar	9-33
Rear U-Bolts	9-33
Spring Hangers	9-35
Spring Mounts	9-11

Tires

Alignment	9-39
Damage	9-39
Matching	9-40
Pressure	9-39
Tread Depth	9-39
Wear Illustrations	9-8
Wheel Hardware	9-41

Transmission

Bolts	9-25
Clutch	9-26
Cooler	9-26
Filter	9-26
Fluid	8-3
Fluid Leaks	9-28
Lines	9-25
Linkage	9-25
Mounts	9-24
Neutral Safety Switch	6-8
Shifter, Automatic	6-7
Shifter, Manual	6-8

Windows

Glass	6-41
Latches/Operation	6-42
Visibility/Fogging	6-42
Washer Fluid	8-3
Wipers	6-24

